

2018 Kentucky Residential Code

First Edition

June 2018



As Adopted by:

Department of Housing, Buildings and Construction

101 Sea Hero Road, Suite 100

Frankfort, Kentucky 40601-5412

Telephone: (502) 573-0365

FAX: (502) 573-1057

Telephone: (502) 573-0365 FAX: (502) 573-1057

PREFACE

The *Kentucky Residential Code (KRC)* is essentially *the 2015 International Residential Code* published by the International Code Council, Inc., with the specific Kentucky amendments. It provides minimum standards to ensure the public safety, health and welfare insofar as they are affected by building construction, and to secure safety to life and property from all hazards incident to the occupancy of buildings, structures, or premises. This edition presents the code with changes approved by the Kentucky Department of Housing, Buildings and Construction through April 2018.

The Kentucky Residential Code is a “mini/maxi” code, in that it establishes minimum and maximum building code requirements for detached single-family dwellings, two-family dwellings and townhouses and no local government shall adopt or enforce any other building code on these units.

The *Kentucky Residential Code* may be amended from time to time by the Department of Housing, Buildings and Construction through the regulatory process by considering proposals from code enforcement officials, industry, and design professionals, and other interested persons and organizations. Amendments are discussed during open meetings of the Housing, Buildings and Construction Advisory Committee. Approved amendments by the Department and the Legislative Review Commission are printed in the Kentucky Administrative Register and posted on the Department’s website (dhbc.ky.gov).

**SAMPLE ORDINANCE FOR ADOPTION OF THE
INTERNATIONAL
RESIDENTIAL CODE FOR
SINGLE FAMILY DWELLINGS**

ORDINANCE NO. _____

An ordinance of the _____ adopting the 2018 edition of *the Kentucky Residential Code*, regulating and controlling the design, construction, quality of materials, erection, installation, alteration, repair, location, relocation, replacement, addition to, use or maintenance of one- and two-family dwellings and townhouses in the _____; providing for the issuance of permits and collection of fees therefore when used with money; repealing Ordinance No. of the _____ and all other ordinances and parts of the ordinances in conflict therewith.

The _____ of the _____ does ordain as follows:

Section 1. That certain documents, three (3) copies of which are on file in the office of the _____ **KEEPER of RECORDS** _____ and the _____, being marked and designated as *Kentucky Residential Code*, is hereby adopted as the code of the _____ for regulating the design, construction, quality of materials, erection, installation, alteration, repair, location, relocation, replacement, addition to, use or maintenance of one- and two-family dwellings and townhouses not more than three stories in height in the _____ and providing for the issuance of permits and collection of fees therefore; and each and all of the regulations, provisions, conditions and terms of such *Kentucky Residential Code*, 2018 edition, on file in the office of the _____ are hereby referred to, adopted and made a part hereof as if fully set out in this ordinance.

Section 2. The following sections are hereby revised:

Section R101.1 Insert: [NAME OF JURISDICTION]

Table R301.2(l) Insert: [APPROPRIATE DESIGN CRITERIA]

Section 3. That Ordinance No. _____ of _____ entitled (fill in here the complete title of the present ordinance or ordinances in effect at the present time so that they will be repealed by definite mention) and all other ordinances or parts of ordinances in conflict herewith are hereby repealed.

Section 4. That if any section, subsection, sentence, clause or phrase of this ordinance is, for any reason, held to be unconstitutional, such decision shall not affect the validity of the remaining portions of this ordinance. The

_____ hereby declares that it would have passed this ordinance, and each section, subsection, clause or phrase thereof, irrespective of the fact that any one or more sections, subsections, sentences, clauses and phrases be declared unconstitutional.

Section 5. That the [**JURISDICTION'S—KEEPER OF RECORDS-**] is hereby ordered and directed to cause this ordinance to be published. (An additional provision may be required to direct the number of times the ordinance is to be published and to specify that it is to be in a newspaper in general circulation. Posting may also be required.)

Section 6. That this ordinance and the rules, regulations, provisions, requirements, orders and matters established and adopted hereby shall take effect and be in full force and effect _____ from and after the date of its final passage and adoption.

TABLE OF CONTENTS

CHAPTER 1		CHAPTER 7	
SCOPE AND ADMINISTRATION	1	WALL COVERING	33
Section		Section	
R101 General.....	1	R703 Exterior Covering	33
R102 Applicability	1		
R103 Department of Building Safety	2	CHAPTER 9	
R104 Duties and Powers of Building Official	2	ROOF ASSEMBLIES	35
R105 Permits	2	Section	
R106 Construction Documents.....	3	R905 Requirements for Roof Coverings	35
R107 Temporary Structures and Uses	3		
R108 Fees	4	CHAPTER 11	
R109 Inspections	4	ENERGY EFFICIENCY	
R110 Certificate of Occupancy.....	4	Section	
R111 Service Utilities.....	4	N1101 General.....	36
R112 Appeals	5		
R113 Violations	6	CHAPTER 13	
R114 Stop Work Order.....	6	GENERAL MECHANICAL SYSTEMS	
R115 Proof of Insurance	6	REQUIREMENTS	
R116 Effective Dates.....	6	Section	
		M1301 General.....	38
CHAPTER 2		M1305 Appliance Access	38
DEFINITIONS	7		
Section		CHAPTER 14	
R202 Definitions	7	HEATING AND COOLING EQUIPMENT AND	
		APPLIANCES.....	39
CHAPTER 3		Section	
BUILDING PLANNING	9	M1403 Heat Pump Equipment	39
Section		M1411 Heating and Cooling Equipment	39
R301 Design Criteria.....	9	M1416 Mini-Split Heat Pumps	39
R302 Fire-Resistant Construction.....	13		
R307 Toilet, Bath and Shower Spaces.....	15	CHAPTER 15	
R310 Emergency Escape and Rescue Openings.....	15	EXHAUST SYSTEMS	40
R311 Means of Egress	15	Section	
R312 Guards and Window Fall Protection	16	M1502 Clothes Dryer Exhaust	40
R313 Automatic Fire Sprinkler Systems	17	M1503 Range Hoods.....	40
R326 Swimming Pools, Spas and Hot Tubs	17		
R327 Post and Frame Structures.....	18	CHAPTER 16	
R328 Tiny Houses	23	DUCT SYSTEMS	41
		Section	
CHAPTER 4		M1601 Duct Construction	41
FOUNDATIONS	25		
Section		CHAPTER 17	
R401 General.....	25	COMBUSTION AIR	42
R403 Footings.....	25		
R404 Foundations and Retaining Walls	28		
CHAPTER 5			
FLOORS	31		
Section			
R502 Wood Floor Framing.....	31		
R507 Exterior Decks.....	31		
CHAPTER 6			
WALL CONSTRUCTION	32		
Section			
R602 Wood Wall Framing.....	32		

CHAPTER 18	
CHIMNEYS AND VENTS	42
CHAPTER 19	
SPECIAL APPLIANCES, EQUIPMENT AND SYSTEMS	42
CHAPTER 20	
BOILERS AND WATER HEATERS	42
CHAPTER 24	
FUEL GAS	42
CHAPTER 25	
PLUMBING ADMINISTRATION	42
CHAPTER 26	
GENERAL PLUMBING REQUIREMENTS	42
CHAPTER 27	
PLUMBING FIXTURES	42
CHAPTER 28	
WATER HEATERS	42
CHAPTER 29	
WATER SUPPLY AND DISTRIBUTION	42
CHAPTER 30	
SANITARY DRAINAGE	42
CHAPTER 31	
VENTS	42
CHAPTER 32	
TRAPS	43
CHAPTER 33	
STORM DRAINS	43

CHAPTER 34	
GENERAL REQUIREMENTS	43
CHAPTER 35	
ELECTRICAL DEFINITIONS	43
CHAPTER 36	
SERVICES	43
CHAPTER 37	
BRANCH CIRCUIT AND FEEDER REQUIREMENTS	43
CHAPTER 38	
WIRING METHODS	43
CHAPTER 39	
POWER AND LIGHTING DISTRIBUTION	43
CHAPTER 40	
DEVICES AND LUMINARIES	43
CHAPTER 41	
APPLIANCE INSTALLATION	43
CHAPTER 42	
SWIMMING POOLS	43
CHAPTER 43	
CLASS 2 REMOTE-CONTROL, SIGNALING AND POWER-LIMITED CIRCUITS	43
CHAPTER 44	
REFERENCED STANDARDS	44

**CHAPTER 1
ADMINISTRATION**

**SECTION R101
GENERAL**

R101.1 Title. These provisions shall be known as the *Kentucky Residential Code for One- and Two-family Dwellings* and shall be cited as such and will be referred to herein as "this code."

R101.2 Scope. The provisions of the *Kentucky Residential Code for One- and Two-family Dwellings* shall apply to the construction, *alteration*, movement, enlargement, replacement, repair, equipment, use and occupancy, location, removal and demolition of detached one- and two-family dwellings and townhouses not more than three stories above *grade plane* in height with a separate means of egress and their *accessory structures*

Exceptions:

1. Live/work units complying with the requirements of Section 419 of the *Kentucky Building Code* shall be permitted to be built as one- and two-family *dwellings* or townhouses. Fire suppression required by Section 419.5 of the *Kentucky Building Code* when constructed under the *International Residential Code for One- and Two-family Dwellings* shall conform to Section P2904.
2. Owner-occupied lodging houses with five or fewer guestrooms shall be permitted to be constructed in accordance with the *Kentucky Residential Code for One- and Two-family Dwellings* when equipped with a fire sprinkler system in accordance with Section P2904.
3. *Farm* dwellings and other buildings and structures located on *farms* which are incident to the operation of the *farm* and located outside the boundary of a municipality; but only if they are not used in the business of retail trade, as a regular place of work for 10 or more people or for the processing or storage of timber products.
4. *Manufactured homes* constructed under federal HUD standards. However, the exterior electric, water and sewer connections and additions to the home are not exempt.
5. *Swimming pools* constructed completely above grade.

R101.3 Intent. The purpose of this code is to establish minimum and maximum requirements to safeguard the public safety, health and general welfare through affordability, structural strength, means of egress facilities, stability, sanitation, light and ventilation, energy conservation and safety to life and property from fire and other hazards attributed to the built environment and to provide safety to fire fighters and emergency responders during emergency operations. No local government shall adopt or enforce any other building code for detached single family dwellings, two-family dwellings and townhouses.

R101.4 Other residential buildings. Multiple single-family dwellings (townhouses) over three stories above grade in height or without separate entrances shall comply with the Kentucky Building Code (KBC).

R101.5 Accepted practices. In the absence of provisions not specifically contained in this code or final decisions of the appeals board, the specification and standards listed in Chapter 44 shall be deemed to represent accepted engineering practice with respect to materials, equipment, systems or method of construction as specified and shall be acceptable.

R101.6 Licensed HVAC contractors. All work involving HVAC as defined and required by KRS Chapter 198B shall be provided by a licensed Journeyman HVAC Mechanic working under the supervision of a licensed Master HVAC Contractor. The building official will require proof of licensure when making inspections.

R101.7 Plumbing contractors and inspections. All plumbing installations shall be performed under the supervision of a Kentucky Licensed Master Plumber according to law and shall be inspected and approved by the state plumbing inspector prior to usage pursuant to KRS Chapter 318 and 815 KAR Chapter 20. The building official will require proof of licensure when making inspections.

R101.8 Electrical contractors and inspections. All electrical installations shall be performed by licensed electricians according to law and shall be inspected by a certified electrical inspector pursuant to KRS 227.489 and KAR 35:015. The building official will require proof of licensure when making inspections.

**SECTION R102
APPLICABILITY**

R102.2 Other laws. The provisions of this code shall not be deemed to nullify any provisions of local, state or federal law. Other local, state or federal law shall be consulted to determine the existence of other powers given to the code official, such as those related to demolition or authority over unsafe structures; however, no local ordinance shall establish any additional or contradictory building construction standard than those adopted in this code.

R102.5 Appendices. Provisions in the appendices of the 2016 Kentucky Residential Code shall not apply unless specifically referenced in the adopting ordinance.

R102.5.1 Appendix K, Sound transmission. The provisions found in Appendix K shall apply to wall and floor-ceiling assemblies separating dwelling units including those separating townhouses.

R102.5.2 Appendix R, Light Straw-Clay Construction. The provisions found in Appendix R shall apply to light

straw clay construction as a nonbearing building material and wall infill systems.

R102.5.3 Appendix S, Strawbale Construction. The provisions found in Appendix S provides prescriptive and performance-based requirements for the use of baled straw as a building material.

R102.7 Existing structures. The legal occupancy of any structure existing on the date of adoption of this code shall be permitted to continue without change, except as is specifically covered in this code, the locally adopted property maintenance code, or as is deemed necessary by the *building official* for the general safety and welfare of the occupants and the public.

R102.8 Plumbing. The provisions of the Kentucky State Plumbing Code shall apply to the installation, alteration, repair and replacement of plumbing systems, including equipment, appliances, fixtures, fittings and appurtenances.

R102.9. Electrical. The electrical system shall be installed in compliance with NFPA 70 as adopted by the Commonwealth of Kentucky.

**SECTION R103
DEPARTMENT OF BUILDING SAFETY**

R103.2.1 Certified inspectors. The local government shall provide at least one Kentucky Certified Building Inspector, Level I, pursuant to 815 KAR 7:070, and certified electrical inspector, certified according to 815 KAR 35:015. The local government shall report the name of all inspectors to the Department and the Department shall be notified of any changes in inspection personnel. To enforce the residential code only, the local government shall provide at least one inspector that has achieved 1 & 2 Family Dwelling Certification.

R103.3 Deputies. In accordance with the prescribed procedures of this *jurisdiction* and with the concurrence of the appointing authority, the *building official* shall have the authority to appoint a deputy *building official*, the related technical officers, inspector, plan examiners and other employees. Such employees shall have powers as delegated by the *building official*. These appointments shall meet the requirements of 815 KAR 7:070 for certification associated with their job duties.

**SECTION R104
DUTIES AND POWERS OF THE BUILDING
OFFICIAL**

R104.7 Department records. The *building official* shall keep official records of applications received, permits and certificates issued, fees collected, reports of inspections, and notices and orders issued. Such records shall be retained in the official records for the period required for the retention of public records as promulgated by the

Kentucky Department of Libraries and Archives pursuant to KRS 171.450.

R104.10.1 Flood hazard areas. The *building official* shall not grant modifications to any provision related to flood hazard areas as established by local jurisdiction without the granting of a variance to such provisions by the board of appeals.

**SECTION R105
PERMITS**

R105.2 Work exempt from permit. Exemption from permit requirements of this code shall not be deemed to grant authorization for any work to be done in any manner in violation of the provisions of this code or any other laws or ordinances of this jurisdiction. Permits shall not be required for the following:

Building:

1. One-story detached *accessory structures* used as tool and storage sheds, playhouses and similar uses, provided the floor area does not exceed 200 square feet (18.58 m²).
2. Fences not over 7 feet (1829 mm) high.
3. Retaining walls that are not over 4 feet (1219 mm) in height measured from grade at the bottom of the wall to the top of the wall.
4. Water tanks supported directly upon *grade* if the capacity does not exceed 5000 gallons (18927L) and the ratio of height to diameter or width does not exceed 2 to 1.
5. Sidewalks and driveways.
6. Painting, papering, tiling, carpeting, cabinets, counter tops and similar finish work.
7. Swings and other playground equipment.
8. Window awnings supported by an exterior wall which do not project more than 54 inches (1372 mm) from the exterior wall and do not require additional support.
9. Decks not exceeding 200 square feet (18.58 m²) in area, that are not more than 30 inches (762mm) above *grade* at any point, are not attached to a *dwelling* and do not serve the exit door require by Section R311.4.

Electrical:

1. Listed cord-and-plug connected temporary decorative lighting.
2. Reinstallation of attachment plug receptacles but not the outlets therefor.
3. Replacement of branch circuit overcurrent devices of the required capacity in the same location.
4. Electrical wiring, devices, appliances, apparatus or equipment operations at less than 25 volts and not capable of supplying more than 50 watts of energy.
5. Minor repair work, including the replacement of lamps or the connection of approved portable electrical equipment to approved permanently installed receptacles.
6. The provisions of this code shall not apply to electrical equipment used for radio and television transmissions.

7. The installation of any temporary system required for the testing or servicing of electrical equipment or apparatus.

Gas:

1. Portable heating appliance.
2. Replacement of any minor part that does not alter approval of equipment or make such equipment unsafe.
3. Portable-fuel-cell appliances that are not connected to a fixed piping system and are not interconnected to a power grid.

Mechanical:

1. Portable heating appliance;
2. Portable ventilation equipment;
3. Portable cooling unit;
4. Steam, hot or chilled water piping within any heating or cooling equipment regulated by this code.
5. Replacement of any part which does not alter its approval or make it unsafe.
6. Portable evaporative cooler;
7. Self-contained refrigeration system containing 10 pounds (4.54 kg) or less of refrigerant and actuated by motors of 1 horsepower (746 W) or less.
8. Portable-fuel-cell appliances that are not connected to a fixed piping system and are not interconnected to a power grid.

Plumbing

1. The stopping of leaks in drains, water, soil, waste or vent pipe; provided, however, that if any concealed trap, drainpipe, water, soil, waste or vent pipe becomes defective and it becomes necessary to remove and replace the same with new material, such work shall be considered as new work and a permit shall be obtained and inspection made as provided in this code.
2. The clearing of stoppages or the repairing of leaks in pipes, valves or fixtures, and the removal and reinstallation of water closets, provided such repairs do not involve or require the replacement or rearrangement of valves, pipes or fixtures.

R105.3 Application for permit. To obtain a *permit*, the applicant shall first file an application in writing on a form furnished for that purpose by the department of building safety. Such application shall:

1. Identify and describe the work to be covered by the *permit* for which application is made.
2. Describe the land on which the proposed work is to be done by legal description, street address or similar description that will readily identify and definitely locate the proposed building or work. New building or additions shall be accompanied by a copy of the current site survey bearing the seal and of a Kentucky Registered Land Surveyor, except the *building official* may, at the *building official's* discretion, accept other proof of location.
3. Indicate the use and occupancy for which the proposed work is intended.
4. Be accompanied by *construction documents* and other information as required by Section 106.1.

5. Give such other data and information as required by the building official.

**SECTION R106
CONSTRUCTION DOCUMENTS**

R106.1 Submittal documents. Submittal documents consisting of *construction documents*, and other data shall be submitted in two or more sets with each application for a *permit*. Where special conditions exist, the *building official* is authorized to require additional *construction documents* to be prepared by a licensed *design professional*.

Exception: The *building official* is authorized to waive the submission of *construction documents* and other data not required to be prepared by a licensed *design professional* if it is found that the nature of the work applied for is such that reviewing of *construction documents* is not necessary to obtain compliance with this code.

R106.1.3 Information on construction in flood hazard areas. For buildings and structures located in whole or in part in flood hazard areas as established by local jurisdiction or floodplain manager floor construction documents shall include:

1. Delineation of flood hazard areas, floodway boundaries and flood zones and the design flood elevation, as appropriate.
2. The elevation of the proposed lowest floor, including *basement*; in areas of shallow flooding (AO zones), the height of the proposed lowest floor, including *basement*, above the highest adjacent grade; and
3. The elevation of the bottom of the lowest horizontal structural member in coastal high hazard areas (V zone); and
4. If design flood elevations are not included on the community's Flood Insurance Rate Map (FIRM), the *building official* and the applicant shall obtain and reasonably utilize any design flood elevation and floodway data available from other sources.

R106.2 Site plan or plot plan. The *construction documents* submitted with the application for *permit* shall be accompanied by a site plan showing the size and location of new construction and existing structures on the site and distances from *lot lines*, the established street grades and the proposed finished grades; and it shall be drawn in accordance with an accurate boundary line survey. In the case of demolition, the site plan shall show construction to be demolished and the location and size of existing structures and construction that are to remain on the site or plot. The *building official* is authorized to waive or modify the requirement for a site plan when the application for permit is for alteration or repair or when otherwise warranted.

106.5 Retention of construction documents. The *building official*, as required by the Kentucky Department of Libraries and Archives administrative regulations, shall retain approved construction documents.

SECTION R107 TEMPORARY STRUCTURES AND USES

R107.3 Temporary power. The *building official* and/or the applicable licensed and certified inspector listed in Section 101.8 are authorized to give permission to temporarily supply and use power in part of an electric installation before such installation has been fully completed and the final certificate of completion has been issued. The part covered by the temporary certificate shall comply with the requirements specified for temporary lighting, heat or power in NFPA 70.

SECTION R108 FEES

R108.6 Work commencing before permit issuance. Any person who commences any work on a building, structure, electrical, gas, mechanical or plumbing system before obtaining the necessary *permits* may be subject to penalties established in KRS Chapters 198B, 227, 227A, 234, 236 and 318. The fee shall be in addition to and equal to the amount of the original fee.

R108.7 Accounting. The *building official* shall keep an accurate account of all fees collected and such collected fees shall be deposited monthly in the jurisdiction treasury, or otherwise disposed of as required by law.

SECTION R109 INSPECTIONS

R109.1 Types of inspections. For onsite construction, from time to time the *building official*, upon notification from the *permit* holder or his agent, shall make or cause to be made any necessary inspections and shall either approve that portion of the construction as completed or shall notify the *permit* holder or his or her agent wherein the same fails to comply with this code. Approval as a result of an inspection shall not be construed to be an approval of a violation of the provisions of this code or of other ordinances of the jurisdiction. Inspections presuming to give authority to violate or cancel the provisions of this code or of other ordinances of the jurisdiction shall not be valid. It shall be the duty of the permit applicant to cause the work to remain accessible and exposed for inspection purposes. Neither the building official nor the jurisdiction shall be liable for expense entailed in the removal or replacement of any material required to allow inspection.

R109.1.3 Floodplain inspections. For construction in areas prone to flooding as established by local jurisdiction, upon placement of the lowest floor, including *basement*, and prior to further vertical construction, the *building official* shall require submission of documentation, prepared and sealed by a registered *design professional*, of the elevation of the lowest floor, including *basement*, required in Section R322.

R109.1.6 Final inspections. Upon completion of the

building, the owner or agent of the facility shall request a final inspection. The *building official* shall set a time for the inspection and notify the owner or agent. If substantial compliance with the approved construction documents and *permit* has been achieved, a certificate of occupancy shall be issued, as described in Section R110. If compliance has not been achieved, violations of the approved construction documents and *permit* shall be noted and immediately communicated to the owner, agency and other person holding the *permit*. It shall be the owner's responsibility and the responsibility of the person responsible for the construction work to fulfill any compliance deficiencies noted.

R109.1.7 Industrialized building system inspections. The inspection of all buildings classified as *industrialized building systems*, regardless of size or occupancy classification, shall be in accordance with this section.

R109.1.7.1 Off-site construction. In-plant inspections in production and manufacturing facilities for *industrialized building systems* shall be conducted by the Department or its authorized agent.

R109.1.7.2 On-site construction. On-site construction related to modular homes or one- and two-family dwelling installations may be permitted and inspected by the local *building official* having *jurisdiction* upon notice from the Department of an approved modular home. The local code official having *jurisdiction* shall be responsible for inspection of the foundation system, placement of the building, connection of the units, final set-up of the units and issuance of the certificate of occupancy. The local *building official* shall be responsible for inspection of these systems for zoning, water supply and sewage disposal, and other applicable local ordinance purposes.

SECTION R110 CERTIFICATE OF OCCUPANCY

R110.2 Change in use. Changes in the character or use of an existing structure shall not be made except as specified in Sections 3408 and 3409 of the *Kentucky Building Code*.

SECTION R111 SERVICE UTILITIES

R111.1 Connection of service utilities. No person shall make connections from a utility, source of energy, fuel or power to any building or system that is regulated by this code for which a *permit* is required, until *approved* by the *building official* and/or the applicable licensed and certified inspector listed in sections R101.6, R101.7 and R101.8.

R111.2 Temporary connection. The *building official* and/or the applicable licensed and certified inspector listed in

section R101.6, R101.7 and R101.8 shall have the authority to authorize and approve the temporary connection of the building or system to the utility, source of energy, fuel or power.

R111.3 Authority to disconnect service utilities. The *building official* and/or the applicable licensed and certified inspector listed in section R101.6, R101.7 and R101.8 shall have the authority to authorize disconnection of utility service to the building, structure or system regulated by this code and the referenced codes and standards set forth in Section R102.4 in case of emergency where necessary to eliminate an immediate hazard to life or property or when such utility connection has been made without the approval required by Section R111.1 or R111.2. The *building official* shall notify the serving utility and whenever possible the owner and occupant of the building, structure or service system of the decision to disconnect prior to taking such action if not notified prior to disconnection. The owner or occupant of the building, structure or service system shall be notified in writing as soon as practical thereafter.

SECTION R112 APPEALS

R112.1 General. All appeals from the decisions of code officials shall be conducted in accordance with the appeals provisions of KRS 198B.070. Where a local appeals board exists, a party must first appeal to the local board when aggrieved by a decision of the local code official. The *Department* shall further hear appeals directly from a party aggrieved by the decision of an agent of the Department.

R112.2 Appeal by fire code official. Decisions rendered by the code official with respect to enforcement of the *Kentucky Building Code* on any building may be appealed by the local fire code official of the jurisdiction if the fire code official is aggrieved by that decision.

R112.3 Local appeals board. Local appeals boards may be appointed to hear appeals from the decisions of the local code official in accordance with the provisions of Sections 112.3.1 through 112.3.4.

R112.3.1 Appointment. The mayor or county judge executive of a local government which is enforcing the *Kentucky Building Code* may, upon approval of the local legislative body, appoint a local appeals board, consisting of at least five technically qualified persons with professional experience related to the building industry, three of which shall not be employees of the local government, to hear appeals from the decisions of the local code official regarding building code requirements.

R112.3.2 Cooperative agreements. Local governments which are enforcing the *Kentucky Building Code* may cooperate with each other and provide a local appeals board and shall adhere to the provisions of KRS Chapter 65 when entering into a cooperative agreement.

R112.3.3 Disqualification of member. Local code officials or employees of a local inspection department shall not sit on a local appeals board if the board is hearing an appeal to a decision rendered by the local department. A member of a local appeals board shall not hear an appeal in a case in which the member has a financial interest.

R112.3.4 Right to appeal. Any party to a decision by the local code official may appeal that decision to the local appeals board. Upon receipt of an appeal from a qualified party, the local appeals board shall convene a hearing to consider the appeal within 15 days of receipt.

R112.3.5 Notice of meeting. All parties to the appeal shall be notified of the time and place of the hearing by letter sent by certified mail not later than 10 days prior to the date of the hearing.

R112.3.6 Board decision. The local appeals board shall render a decision within five working days after the hearing. The board may uphold, amend or reverse the decision of the local code official, and there shall be no appeal from the decision of the local appeals board other than by appeal to the *Department*.

R112.3.7 Open hearing. All hearings before the local appeals board shall be open to the public. The appellant, the appellant's representative, the code official and any all persons whose interests are affected shall be given an opportunity to be heard.

R112.3.7.1 Procedure. The local appeals board shall adopt and make available to the public through the secretary procedures under which a hearing will be conducted. The procedures shall not require compliance with strict rules of evidence but shall mandate that only relevant information be received.

R112.3.8 Board decision. The local appeals board shall modify or reverse the decision of the code official by a concurring vote of three members.

R112.4 Appeals to the State. Application for appeal by a property owner may be made when it is claimed in writing that the true intent of this code or the rules legally adopted thereunder have been incorrectly interpreted, the provisions of this code do not fully apply, or an equally good or better form of construction can be used, or that the code official has refused to grant a modification to the provisions of this code covering the manner of construction or material to be used in the erection, alteration or repair of a building or structure.

R112.4.1 Application procedure. Appeals to the *Department* shall be in writing and shall be addressed to the Commissioner of the Department of Housing, Buildings and Construction, 101 Sea Hero Road, Suite 100, Frankfort, Kentucky 40601-5412; Attention: Appeals. The appeal shall include citations of those provisions of the *Kentucky Building Code* that are at issue, an explanation of why the decision of the state code official or local code official

relative to those provisions is being contested and a copy of the decision rendered by the local appeals board, if any.

R112.4.2 Investigation of appeal. The Commissioner shall immediately notify the *Department* or the five-member committee authorized by the Commissioner when an appeal is received. The Commissioner or a designated employee of the *Department* shall then investigate the evidence pertaining to the appeal and, based on the results of the investigation, make written recommendations to the *Department* or committee on the disposition of the case in question, within 30 days.

R112.4.3 Employee deferral. Employees of the *Department* shall not investigate or make recommendations on an appeal to his or her decision, but shall defer in this case to employees who are not party to the decision which led to the appeal.

R112.4.4 Investigative authority. In conducting an investigation, the Commissioner or the designated representatives, acting for the *Department*, shall have the authority to administer oaths and affirmations, issue subpoenas authorized by law, rule upon offers of proof and receive relevant evidence, take or cause depositions to be taken, regulate the course of any hearings they may schedule, and hold conferences for the settlement or simplification of the issue by consent of the parties.

R112.4.5 Administrative hearing. Pursuant to KRS Chapter 13B, if the issue has not been settled by agreement of the parties within limitations set by Section 112.4.2, the *Department* shall schedule an administrative hearing on the matter. The cost of any appeal forwarded to the *Department* because there is no local appeals board shall be borne by the local government. The *Department* shall calculate the actual cost of processing the appeal and bill the local government at the conclusion of all proceedings.

112.4.6 Judicial appeals. Final orders of the *Department* are appealable to the Circuit Court in the county in which the property is located.

SECTION R113 VIOLATIONS

R113.4 Violation penalties. Any person who violates a provision of this code or fails to comply with any of the requirements thereof or who erects, constructs, alters or repairs a building or structure in violation of the *approved construction documents* or directive of the *building official*, or of a *permit* or certificate issued under the provisions of this code, shall be subject to penalties provided by KRS 198B.990 and other applicable law.

SECTION R114 STOP WORK ORDER

R114.4 Limitation on changes. No inspector shall be authorized to require changes on-site that are contrary to the

approved construction documents. If an inspector finds a code discrepancy in an on-site inspection, the inspector shall refer the matter to the official having construction document review responsibility who shall require corrections if the code so requires.

SECTION R115 PROOF OF INSURANCE

R115.1 Compliance with law. The issuance of a building permit shall be contingent upon presentation of proof to the effect that all contractors and subcontractors employed or that will be employed in the construction, alteration or repair under the permit are in compliance with the Kentucky law relating to worker's compensation and unemployment insurance.

R115.2 General applicability. Compliance with this section shall be achieved by presenting certificates or other forms approved by the Kentucky Labor Cabinet to the code official issuing the permit.

SECTION R116 EFFECTIVE DATES

R116.1 General. The *building official* shall accept plans in compliance with the requirements of either the 2013 edition or the 2018 edition of the *Kentucky Residential Code*. Effective January 1, 2019, this code shall be mandatory and no permit shall be issued for construction under any other building code.

CHAPTER 2 DEFINITIONS

SECTION R202 DEFINITIONS

R202 DEFINITIONS. Section R202 Definitions of Habitable Space and Historical Building of the 2015 IRC shall be DELETED in their entirety.

BUILDING. is defined by KRS 198B.010(4) and " means any combination of materials, whether portable or fixed, which comprises a structure or non-mine underground area affording facilities or shelter for any human occupancy, whether infrequent or regular, and also means single-family dwellings, including those sold or constructed under a trade or brand name. The word "building" shall be construed wherever used herein as if followed by the words "or part or parts thereof and all equipment therein" unless the context clearly requires a different meaning. "Building" shall also mean swimming pools constructed below grade on site, but not swimming pools assembled above grade on site. "Building" shall not mean a manufactured home governed by the National Manufactured Housing Construction and Safety Standards Act of 1974, 42 U.S.C. secs. 5401 et seq., or a farm dwelling or other farm buildings and structures incident to the operation and maintenance of the farm if the farm structures are located outside the boundary of a municipality and are not used in the business of retail trade or used as a place of regular employment for ten (10) or more people or structures used in the storage or processing of timber products.

BARRIER. A fence, a *wall*, a building wall, or combination thereof, which completely surrounds the *swimming pool* and obstructs access to the *swimming pool*.

COLLAR BEAM/TIE. A horizontal framing member connecting opposing rafter elements for stability.

COMMISSIONER. Defined by KRS 198B.010 (9) and means the commissioner of the Department of Housing, Buildings and Construction.

DEPARTMENT. means the Department of Housing, Buildings and Construction.

EGRESS ROOF ACCESS WINDOW. A skylight or roof window designed and installed to satisfy the *emergency escape and rescue opening* requirements in Section R310.2.

FARM. Means property having a bona fide agricultural or horticultural use as defined by KRS 132.010(9) and (10) which is qualified by and registered with the property valuation administrator in the county in which the property is located.

HOT TUB. See definition of *private swimming pool*.

INDUSTRIALIZED BUILDING SYSTEM or BUILDING SYSTEM. Is defined by KRS 198B.010 (16) and means any structure or component thereof which is wholly or in substantial part fabricated in an off-site manufacturing facility for installation or assembly on a permanent foundation at the building site.

IN-GROUND POOL. See definition of *private swimming pool*.

KNEE WALL. Any short wall used as a part of the support for a roof structure.

KRS. means the Kentucky Revised Statutes.

LANDING PLATFORM. A landing measuring two treads deep and two risers tall, provided as the top step of a stairway accessing a *loft*.

LOFT. Any floor level located above the main floor and open to it on at least one side, with a *ceiling height* less than 6 feet 8 inches (2032 mm), complying with the area, access, and guard requirements of Section AV104, and used as a living or sleeping space.

MANUFACTURED HOME. is defined by KRS 198B.010 (23) and 227.550 and means a single-family residential dwelling constructed in accordance with the federal act, manufactured after June 15, 1976, and designed to be used as a single-family residential dwelling with or without a permanent foundation when connected to the required utilities, and includes the plumbing, heating, air conditioning, and electrical systems contained therein. The manufactured home may also be used as a place of business, profession, or trade by the owner, the lessee, or the assigns of the owner or lessee and may comprise an integral unit or condominium structure. Buildings the construction of which is not preempted by the federal act are subject to building code requirements of KRS Chapter 198B.

MODULAR HOME. means an industrialized building system which is designed to be used as a residence and which is not a manufactured or mobile home.

ORDINARY REPAIR. is defined by KRS 198B.010 (19) and means any nonstructural reconstruction or renewal of any part of an existing building for the purpose of its maintenance, or decoration, and shall include but not be limited to the replacement or installation of nonstructural components of the building such as roofing, siding, windows, storm windows, insulation, drywall or lath and plaster, or any other replacement, in kind, that does not alter the structural integrity,

alter the occupancy or use of the building, or affect, by rearrangement, exitways and means of egress; but shall not include additions to, or alteration of, or relocation of any standpipe, water supply, sewer, drainage, gas, soil, waste, vent or similar piping, electric wiring, or mechanical equipment including furnaces and hot water heaters or other work affecting public health or safety.

PERPENDICULAR LUMBER SHEATHING. For the purposes of this code, any lumber sheathing, either spaced or laid side-by-side having an angle of intersection with the rafter or joist of 60 degrees or greater.

PRIVATE SWIMMING POOL. Any *structure* that contains water over 24 inches (610 mm) deep and which:

- a. is used, or intended to be used, for swimming or recreational bathing in connection with a Group R-3 occupancy; and
- b. is available only to the family and guests of the householder. This includes *swimming pools* constructed below grade on *site*, but not those assembled above grade on *site*.

PRIVATE SWIMMING POOL, OUTDOOR. Any *private swimming pool* that is not an indoor pool.

RATIONAL ANALYSIS. Alternative analytical calculations, experimental data, published design data or other referenced citations that have been approved for use by the building official.

REPAIR. The reconstruction or renewal of any part of an existing building for the purpose of its maintenance. See also “ordinary repair.”

SPA. See definition of *private swimming pool*.

SWIMMING POOL. Any *structure* intended for swimming, recreational bathing or wading that contains water over 24 inches (610 mm) deep. This includes in-ground, pools, hot tubs, spas and fixed-in-place wading pools.

TINY HOUSE. A *dwelling* which is 400 or less square feet (37 m²) in floor area excluding *lofts*.

CHAPTER 3 BUILDING PLANNING

SECTION R301 DESIGN CRITERIA

R301.1.1 Alternative provisions. As an alternative to the requirements in Section R301.1, the following standards are permitted subject to the limitations of this code and the limitations therein. Where engineered design is used in conjunction with these standards the design shall comply with the Kentucky Building Code.

1. American Forest and Paper Association (AF&PA) Wood Frame Construction Manual (WFCM).
2. American Iron and Steel Institute (AISI) Standard for Cold-Formed Steel Framing – Prescriptive Method for One-and Two-Family Dwellings (COFS/PM) with Supplement to Standard for Cold-Formed Steel Framing – Prescriptive Method for One-and Two-Family Dwellings.
3. ICC Standard on the Design and Construction of Log Structures (ICC 400).
4. Federal Emergency Management Administration, Homebuilders’ Guide to Earthquake Resistant Construction, FEMA 232-June 2006.
5. American Wood Council Prescriptive Residential Wood Deck Construction Guide (DCA6).
6. National Frame Builders Association Post Frame Building Design Manual.

R301.2 Climatic and geographic design criteria. Buildings shall be constructed in accordance with the provisions of this code as limited by the provisions of this section. Additional criteria shall be established as set forth in Tables R301.2 (1) and R301.2.2.1.

R301.2.2 Seismic provisions. The seismic provisions of this code shall apply to buildings constructed in Seismic Design Categories D₀, D₁, and D₂, as determined in accordance with this section. Buildings in Seismic Design Category E shall be designed in accordance with the Kentucky Building Code, except when the Seismic Design Category is reclassified to a lower Seismic Design Category in accordance with Section R301.2.2.1.

Exceptions: The following types of buildings or structures are exempt from the seismic requirements of this code:

1. Detached one-and two-family dwellings, townhomes and their accessory structures located in Seismic Design Categories A, B or C.
2. Those dwellings which conform to the standards and principles set forth in the “Home Builder’s Guide to Seismic Resistant Construction” issued by the Federal Emergency Management Agency (FEMA) in FEMA 232 (June 2006), which is incorporated by reference.
3. Where exceptions to the required provisions for Seismic Design Categories D₁, and D₂ can be shown to be justified

by implementing the provisions of the Kentucky Building Code, a rational analysis design in accordance to the International Building Code may be used, subject to the approval of the building official.

R301.2.2.1 Determination of seismic design category. Buildings shall be assigned a seismic design category in accordance with Table R301.2.2.1.

R301.2.2.1.1 Alternate determination of seismic design category. The seismic design categories and corresponding short period design spectral response accelerations, S_{DS} shown in Table R301.2.2.1 are based on soil Site Class D, as defined in Section 1613.3.2 of the *Kentucky Building Code*. If soil conditions are other than Site Class D, the short period design spectral response accelerations, S_{DS} , for a site can be determined according to Section 1613.3 of the *Kentucky Building Code*. The value of S_{DS} determined according to Section 1613.3 of the *Kentucky Building Code* is permitted to be used to set the seismic design category according to Table R301.2.2.1.1, and to interpolate between values in Tables R602.10.1.3, R603.9.2(1) and other seismic design requirements of this code.

R301.2.2.1.2 Alternative determination of Seismic Design Category E. Section R301.2.2.1.2 of the 2015 IRC shall be DELETED in its entirety.

R301.2.2.4 Seismic Design Category E. Section R301.2.2.4 of the 2015 IRC shall be DELETED in its entirety.

R301.2.2.2.5 Irregular buildings. Prescriptive construction as regulated by this code shall not be used for irregular structures located in Seismic Design Categories D₀, D₁ and D₂. Irregular portions of structures shall be designed in accordance with accepted engineering practice to the extent the irregular features affect the performance of the remaining structural system. When the forces associated with the irregularity are resisted by a structural system designed in accordance with accepted engineering practice, design of the remainder of the building shall be permitted using the provisions of this code. A building or portion of a building shall be considered to be irregular when one or more of the following conditions occur:

1. When shear wall lines or braced wall panels are not in one plane vertically from the foundation to the uppermost story in which they are required.

Exception: For wood light-frame construction, floors with cantilevers, offsets, or setbacks not exceeding four times the nominal depth of wood floor joists are permitted to support braced wall panels that are out of plane with braced wall panels below provided that:

TABLE R301.2 (1)
DESIGN SNOW, CLIMATIC AND GEOMETRIC DESIGN CRITERIA FOR KENTUCKY COUNTIES

COUNTY	GROUND SNOW LOAD p_g (psf) ^a	COUNTY	GROUND SNOW LOAD p_g (psf) ^a	COUNTY	GROUND SNOW LOAD p_g (psf) ^a	COUNTY	GROUND SNOW LOAD p_g (psf) ^a
Adair	15	Edmonson	15	Knox	15	Nicholas	15
Allen	15	Elliott	15	Larue	15	Ohio	15
Anderson	15	Estill	15	Laurel	15	Oldham	15
Ballard	15	Fayette	15	Lawrence	15	Owen	15
Barren	15	Fleming	15	Lee	15	Owsley	15
Bath	15	Floyd	20	Leslie	20	Pendleton	15
Bell	15 ^b	Franklin	15	Letcher	20 ^c	Perry	15
Boone	20	Fulton	15	Lewis	20	Pike	15
Bourbon	15	Gallatin	20	Lincoln	15	Powell	15
Boyd	20	Garrard	15	Livingston	15	Pulaski	15
Boyle	15	Grant	20	Logan	15	Robertson	15
Bracken	20	Graves	15	Lyon	15	Rockcastle	15
Breathitt	15	Grayson	15	Madison	15	Rowan	15
Breckinridge	15	Green	15	Magoffin	15	Russell	15
Bullitt	15	Greenup	20	Marion	15	Scott	15
Butler	15	Hancock	15	Marshall	15	Shelby	15
Caldwell	15	Hardin	15	Martin	20	Simpson	15
Calloway	15	Harlan	15 ^b	Mason	20	Spencer	15
Campbell	20	Harrison	15	McCracken	15	Taylor	15
Carlisle	15	Hart	15	McCreary	15	Todd	15
Carroll	20	Henderson	15	McLean	15	Trigg	15
Carter	15	Henry	20	Meade	15	Trimble	20
Casey	15	Hickman	15	Menifee	15	Union	15
Christian	15	Hopkins	15	Mercer	15	Warren	15
Clark	15	Jackson	15	Metcalfe	15	Washington	15
Clay	15	Jefferson	15	Monroe	15	Wayne	15
Clinton	15	Jessamine	15	Montgomery	15	Webster	15
Crittenden	15	Johnson	15	Morgan	15	Whitley	15
Cumberland	15	Kenton	20	Muhlenberg	15	Wolfe	15
Daviess	15	Knott	20	Nelson	15	Woodford	15
WIND DESIGN	Basic ultimate wind speed, V_{ult} shall be 115 mph (51.4 m/s) for all Kentucky counties. Topographic effects shall be investigated. ^{d, e}						
SEISMIC DESIGN CATEGORY	Seismic Design Category shall be in accordance with Table R301.2.2.1.						
WEATHERING	Weathering probability for concrete shall be classified as SEVERE for all Kentucky counties and meet requirements of Table R402.2.						
FROST LINE DEPTH	Frost depth shall be in accordance to Table 403.1.4.						
TERMITE PROTECTION	Termite infestation probability shall be MODERATE TO HEAVY for all Kentucky counties.						
FLOOD HAZARDS	Buildings in identified floodways shall be designed in accordance to Section R301.2.4.						

TABLE R301.2 (1)

DESIGN SNOW, CLIMATIC AND GEOMETRIC DESIGN CRITERIA FOR KENTUCKY COUNTIES (continued)

For SI: 1 pound per square foot (psf) = 0.0479 kN/m².

- a. Listed values of ground snow load, p_g , shall be used in accordance to Section R301.2.3 of this code.
- b. Ground snow load values for elevations above 2600 feet (792.480 m) in this county shall be based on site-specific case studies or by other approved means of rational analysis.
- c. Ground snow load values for elevations above 2500 feet (762 m) in this county shall be based on site-specific case studies or by other approved means of rational analysis.
- d. See Section 301.2.1.3 for conversion to nominal design wind speeds, V_{asd} when reference documents are based on nominal or ASD speeds.
- e. See Section 602.12 for alternative methods for wind design

1. Floor joists are nominal 2 inches by 10 inches (51 mm by 254 mm) or larger and that: spaced not more than 16 inches (406 mm) on center.
 2. The ratio of the back span to the designed cantilever is at least 2 to 1.
 3. Floor joists at ends of braced wall panels are doubled.
 4. For wood-frame construction, a continuous rim joist is connected to ends of all cantilever joists. When spliced, the rim joists shall be spliced using a galvanized metal tie not less than 0.58 inch (1.5mm) (16 gage) and 1 ½ inches (38mm) wide fastened with six 16d nails on each side of the splice or a block of the same size as the rim joist of sufficient length to fit securely between the joist space at which the splice occurs, fastened with eight 16d nails on each side of the splice; and
 5. Gravity loads carried at the end of cantilevered joists are limited to uniform wall and roof loads and the reactions from headers having a span of 8 feet (2438mm) or less.
2. When a section of floor or roof is not laterally supported by shear walls or *braced wall panels* on all edges.

Exceptions:

1. Portions of floors that do not support shear walls or braced wall panels above, or roofs, shall be permitted to extend no more than 6 feet (1829 mm) beyond a shear wall or braced wall line.
2. Portions of floors that do not support shear walls or braced wall panels above or roofs, shall be permitted to extend no more than 25 feet (7620mm) or two-thirds of the width of the cantilever portion, whichever is less, beyond a shear wall or braced wall line provide that:
 - a. If a roof deck, the overhang is continuously braced by a wood truss designed for the

lateral load effects of the overhang, or the shear walls or braced wall panels between the roof deck and ceiling. The bracing element shall be directly over the line of the lower braced wall system.

- b. All unsupported deck edges are continuously blocked and all edges are nailed with 8d common nails on not greater than 6" (152mm) on centers.
 - c. A continuous double rim joist matching the dimensions of the joists, purlins or rafters is provided along the three open sides.
3. When the end of a braced wall panel occurs over an opening in the wall below and ends at a horizontal distance greater than 1 foot (305 mm) from the edge of the opening. This provision is applicable to shear walls and braced wall panels offset in plane and to braced wall panels offset out of plane as permitted by the exception to item 1 above.

Exception: For wood light-frame wall construction, one end of a braced wall panel shall be permitted to extend more than 1 foot (305 mm) over an opening not more than 8 feet (2438 mm) wide in the wall below provided that the opening includes a header in accordance with the following:

1. The building width, loading condition and framing member species limitations of Table R502.5(1) shall apply and
2. Not less than one 2x12 or two 2x10 for an opening not more than 4 feet (1219 mm) wide or
3. Not less than two 2x12 or three 2x10 for an opening not more than 8 feet (1829 mm) wide or
4. Not less than three 2 x 12 or four 2 x 10 for an opening not more than 8 feet (2438 mm) wide and
5. The entire length of the braced wall panel does not occur over an opening in the wall below.

**TABLE R301.2.2.1
SEISMIC DESIGN CATEGORIES-SITE CLASS D**

COUNTY	SEISMIC DESIGN CATEGORY	COUNTY	SEISMIC DESIGN CATEGORY	COUNTY	SEISMIC DESIGN CATEGORY	COUNTY	SEISMIC DESIGN CATEGORY
Adair	B	Edmonson	B	Knox	B	Nicholas	B
Allen	B	Elliott	B	Larue	B	Ohio	C
Anderson	B	Estill	B	Laurel	B	Oldham	B
Ballard	D ₂	Fayette	B	Lawrence	B	Owen	B
Barren	B	Fleming	B	Lee	B	Owsley	B
Bath	B	Floyd	B	Leslie	B	Pendleton	B
Bell	B	Franklin	B	Letcher	B	Perry	B
Boone	A	Fulton	D ₂	Lewis	B	Pike	B
Bourbon	B	Gallatin	B	Lincoln	B	Powell	B
Boyd	B	Garrard	B	Livingston	D ₁	Pulaski	B
Boyle	B	Grant	B	Logan	C	Robertson	B
Bracken	B	Graves	D ₂	Lyon	D ₀	Rockcastle	B
Breathitt	B	Grayson	C	Madison	B	Rowan	B
Breckinridge	C	Green	B	Magoffin	B	Russell	B
Bullitt	B	Greenup	B	Marion	B	Scott	B
Butler	C	Hancock	C	Marshall	D ₁	Shelby	B
Caldwell	D ₀	Hardin	B	Martin	B	Simpson	B
Calloway	D ₁	Harlan	B	Mason	B	Spencer	B
Campbell	A	Harrison	B	McCracken	D ₂	Taylor	B
Carlisle	D ₂	Hart	B	McCreary	B	Todd	C
Carroll	B	Henderson	C	McLean	C	Trigg	D ₀
Carter	B	Henry	B	Meade	B	Trimble	B
Casey	B	Hickman	D ₂	Menifee	B	Union	D ₀
Christian	C	Hopkins	C	Mercer	B	Warren	B
Clark	B	Jackson	B	Metcalfe	B	Washington	B
Clay	B	Jefferson	B	Monroe	B	Wayne	B
Clinton	B	Jessamine	B	Montgomery	B	Webster	C
Crittenden	D ₀	Johnson	B	Morgan	B	Whitley	B
Cumberland	B	Kenton	A	Muhlenberg	C	Wolfe	B
Daviess	C	Knott	B	Nelson	B	Woodford	B

4. When an opening in a floor or roof exceeds the lesser of 12 feet (3657 mm) or 50 percent of the least floor or roof dimension.

Exception: The opening is bounded by braced walls within four feet of the opening on all four sides and running the full height of the structure. The braced walls shall bear on continuous foundations walls or the basement slab.

5. When portions of a floor level are vertically offset.

Exceptions:

1. Framing supported directly by continuous foundations at the perimeter of the building.
2. For wood light-frame construction, floors shall be permitted to be vertically offset when the floor framing is lapped or tied together as required by Section R502.6.1.
3. The offset occurs at a braced wall system over continuous foundations or a basement slab.

6. When shear walls and braced wall lines do not occur in two perpendicular directions.

7. When stories above-grade partially or completely braced by wood wall framing in accordance with Section R602 or steel framing in accordance with Section R603 include masonry or concrete construction.

Exception: Fireplaces, chimneys and masonry veneer as permitted by this code. When this irregularity applies, the entire story shall be designed in accordance with accepted engineering practice.

8. Where only one side of the section is unbraced, the length perpendicular to the unbraced side shall not exceed 25 feet nor have a ratio to the unbraced dimension of 1 for a one-story structure or 0.67 for other structures, whichever is less, provided:

- a. All unsupported deck edges within the section are continuously blocked and all edges are nailed with 8d common nails on not greater than 6-inch (152 mm) on center.
- b. A continuous rim joist matching the dimensions of the joists, purlins or rafters is provided along the unbraced side. On the other three sides, there shall be a continuous joist, rim joist or blocking directly over the braced walls.

SECTION R302 FIRE-RESISTANT CONSTRUCTION

R302.1 Exterior walls. Construction, projections, openings and penetrations of exterior walls of dwellings and accessory buildings shall comply with Table R302.1(1).

Exceptions:

1. Walls, projections, openings or penetrations in walls perpendicular to the line used to determine the *fire separation distance*.
2. Walls of *dwellings* and *accessory structures* located on the same *lot*.
3. Detached tool sheds and storage sheds, playhouses and similar structures exempted from permits are not required to provide wall protection based on location on the *lot*. Projections beyond the *exterior wall* shall not extend over the *lot line*.
4. Detached garages accessory to a *dwelling* located within 2 feet (610 mm) of a *lot line* are permitted to have roof eave projections not exceeding 4 inches (102 mm).
5. Foundation vents installed in compliance with this code are permitted.
6. For building applications that have received local zoning approvals for plats or for preliminary concept or master plans prior to July 1, 2007, dwellings with a *fire separation distance* of less than three (3) feet from the property line shall be required to have at least a one-hour fire resistance rating and exposure from both sides and openings shall not be permitted. Projections and penetrations shall comply with Table R302.1(1).
7. Minimum fire separation distances for exterior walls may be decreased to a minimum of three (3) feet from the property line if the exterior wall of the dwelling on the adjacent site is held by deed or other recorded land restriction at a distance from the property line which affords at least ten (10) feet between the exterior walls of the dwellings. Projections more than 12 inches beyond the exterior wall are prohibited.

Table R302.1 (1)
Exterior Walls

Exterior Wall Element		Minimum Fire-Resistance Rating	Minimum Fire Separation distance
Walls	Fire-resistance rated	1 hour – tested in accordance with ASTM E 119 or UL 263 with exposure from both sides	< 5 feet
	Non fire-resistance rated	0 hours	> 5 feet
Projections	Fire-resistance rated	1 layer 5/8 type exterior sheetrock or other approved material on the underside	> 2 feet to < 4 feet
	Not fire-resistance rated	0 hours	> 5 feet
Openings	Not allowed	N/A	< 3 feet
	25% maximum of wall area ^a	0 hours	< 5 feet to > 3 feet
	Unlimited	0 hours	> 5 feet
Penetrations	All	Comply with Section R302.4	< 5 feet
		None required	> 5 feet
	25% maximum of wall area ^a	0 Hours	< 5 feet to > 3 feet

a. Shall be the aggregate of Openings and Penetrations in walls that are > 3 feet and < 5 feet to a property line.

R302.1.1 Continuity. The fire-resistance rated wall shall be continuous from the foundation to the underside of the roof sheathing, deck or slab, and shall extend the full length of the wall or assembly, to a point where the fire separation distance no longer would require a fire-resistance rating of the exterior wall.

R302.1.2 Parapets. Parapets shall be constructed on exterior walls of buildings in accordance with Section R302.2.3 and R302.3.

Exceptions. A parapet need not be provided on an exterior wall where any of the following conditions exist:

1. The wall is not required to be fire-resistance rated in accordance with Table R302.1(1).
2. When the entire building is provided with a Class C roof covering, the exterior walls shall be permitted to terminate at the underside of the roof sheathing or deck provided:
 - 2.1. The roof sheathing or deck is constructed of approved noncombustible materials or of fire

retardant-treated wood for a distance of 4 feet (1220mm); or

2.2. The roof is protected with one layer of 5/8 (15.9mm) Type X gypsum board directly beneath the roof sheathing or deck, supported by a minimum of nominal 2-inch (51mm) ledgers attached to the sides of the roof framing members for a minimum distance of 4 feet (1220mm).

3. Where the exterior wall is permitted to have a maximum of 25% unprotected openings based on fire separation distance based on Table R302.1(1).

R302.2 Townhouses. Each *townhouse* shall be considered a separate building and shall be separated by fire-resistance-rated wall assemblies meeting the requirements of Section R302.1 for exterior walls.

Exception: A common 2-hour fire-resistance-rated wall assembly tested in accordance with ASTM E 119 or UL 263 is permitted for townhouses if such walls do not contain plumbing or mechanical equipment, ducts or vents in the cavity of the common wall. The wall shall be rated for fire exposure from both sides and shall extend to and be tight

against exterior walls and the underside of the roof sheathing. Electrical installations shall be in accordance with NFPA 70. Penetrations of electrical outlet boxes shall be in accordance with Section R302.4.

R302.5.1 Opening protection. Openings from a private garage directly into a room used for sleeping purposes shall not be permitted. Other openings between the garage and the residence shall be equipped with solid wood doors not less than 1 3/8 inches (35mm) in thickness, solid or honeycomb-core steel doors not less than 1 3/8 inches (35mm) thick, or 20-minute fire-rated doors.

R302.13 Fire protection of floors. Section R302.13 of the 2015 IRC shall be DELETED in its entirety.

SECTION R307 TOILET, BATH AND SHOWER SPACES

R307.3 Blocking. A minimum of 2 x 6 blocking shall be required around toilet, bathtub and shower units at a height not less than 33 inches and not more than 38 inches (838-965 mm) above the finished floor.

SECTION R310 EMERGENCY ESCAPE AND RESCUE OPENINGS

R310.1 Emergency escape and rescue. Every sleeping room shall have at least one operable emergency and rescue opening. Where *basements* contain one or more sleeping rooms, emergency egress and rescue openings shall be required in each sleeping room, but shall not be required in adjoining areas of the basement. Where emergency escape and rescue openings are provided they shall have a sill height of not more than 44 inches (1118 mm) measured from the finished floor to the bottom of the clear opening. Where a door opening having a threshold below the adjacent ground elevation serves as an emergency escape and rescue opening an is provided with a bulkhead enclosure, the bulkhead enclosure shall comply with Section R310.3. The net clear opening dimensions required by this section shall be obtained by the normal operation of the emergency escape and rescue opening from the inside. Emergency escape and rescue openings with a finished sill height below the adjacent ground elevation shall be provided with a window well in accordance with Section R310.2. Emergency escape and rescue openings shall open directly into a public way, or to a yard or court that opens to a public way.

R310.1 Emergency escape and rescue opening required. Section R310.1, Exception of the 2015 IRC shall be DELETED in its entirety.

R310.5 Dwelling additions. Section R310.5 of the 2015 IRC shall be DELETED in its entirety.

R310.6 Alterations or repairs of existing basements. Section R310.6 of the 2015 IRC shall be DELETED in its entirety.

SECTION R311 MEANS OF EGRESS

R311.2 Egress Doors. Not less than one egress door shall be provided for each *dwelling* unit. The egress door shall be side hinged, and shall provide a clear width of not less than 32 inches (813 mm) where measured between the face of the door and the stop, with the door open 90 degrees (1.57 rad). The clear height of the door opening shall be not less than 78 inches (1981 mm) in height measured from the top of the threshold to the bottom of the stop. Other interior egress doors shall have a clear net opening width of not less than 32 (813 mm). Exterior egress doors shall be readily openable from inside the *dwelling* without the use of a key or special knowledge or effort.

R311.3.1 Floor elevations at the required egress doors. Landings or finished floors at the required egress door shall not be more than 1 1/2 inches (38mm) lower than the top of the threshold.

Exception: the landing or floor on the exterior side shall not be more than ~~7 3/4~~ 8 1/4 inches (210mm) below the top of the threshold provided the door does not swing over the landing or floor.

R311.3.2 Floor elevations for other exterior doors. Doors other than the required egress door shall be provided with landings or floors not more than 8 1/4 inches (210mm) below the top of the threshold.

Exception: Other than the required exit door, where the vertical elevation measured between the interior finish floor and the exterior finish grade, patio or deck does not exceed 30 inches, a landing is not required for the exterior side of the door provided the door, other than an exterior storm or screen door, does not swing over the stairway.

R311.4 Vertical egress. Egress from habitable levels shall be by a ramp in accordance with Section R311.8 or a stairway in accordance with Section R311.7.

R311.7.5.1 Risers. The maximum riser height shall be 8 1/4 inches (210 mm). The riser shall be measured vertically between leading edges of the adjacent treads. The greatest riser height within any flight of stairs shall not exceed the smallest by more than 3/8 inch (9.5 mm). Risers shall be vertical or sloped from the underside of the nosing of the tread above at an angle not more than 30 degrees (0.51 rad) from the vertical. Open risers are permitted provided that the opening between the treads does not permit the passage of a 4-inch (102mm) diameter sphere.

Exception: The opening between adjacent treads is not limited on stairs with a total rise of 30 inches (762mm) or less.

R311.7.5.2 Treads. The minimum tread depth shall be 9

inches (229 mm). The tread depth shall be measured horizontally between the vertical planes of the foremost projection of adjacent treads and at a right angle to the tread's leading edge. The greatest tread depth within any flight of stairs shall not exceed the smallest by more than 3/8 inch (9.5 mm).

R311.7.5.2.1 Winder treads. Winder treads shall have a minimum tread depth of 9 inches (229 mm) measured between the vertical planes of the foremost projection of adjacent treads at the intersections with the walk line. Winder treads shall have a minimum tread depth of 6 inches at any point within the clear width of the stair. Within any flight of stairs, the largest winder tread depth at the walk line shall not exceed the smallest winder tread by more than 3/8 inch (9.5mm). Consistently shaped winders at the walk line shall be allowed within the same flight of stairs as rectangular treads and do not have to be within 3/8 inch (9.5mm) of the rectangular tread depth.

R311.7.8.2 Continuity. Handrails for stairways shall be continuous for the full length of the flight, from a point directly above the top riser of the flight to a point directly above the lowest riser of the flight. Handrail ends shall be returned or shall terminate in newel posts or safety terminals. Handrails adjacent to a wall shall have a space of not less than 1 1/2 inch (38) between the wall and the handrails.

Exceptions:

1. Handrails shall be permitted to be interrupted by a newel post at the turn.
2. The use of a volute, turnout, starting easing or starting newel shall be allowed over the lowest tread.
3. Handrails within a dwelling unit shall be permitted to be discontinuous between the top and bottom of a flight of stairs where the ends of the discontinued rail are returned to a wall or post and the maximum distance between the ends of discontinued rails is not greater than 4 inches (102 mm).

R311.7.8.3 Grip-size. All required handrails shall be of one of the following types or provide equivalent graspability.

1. **Type I.** Handrails with a circular cross section shall have an outside diameter of at least 1 1/4 inches (32 mm) and not greater than 2 5/8 inches (67 mm). Other handrail shapes, including those complying with Figure R311.7 (a-f) are considered to be equivalent in graspability. If the handrail is not

circular it shall have a perimeter dimension of at least 4 inches (102 mm) and not greater than 6 1/4 inches (160 mm) with a maximum cross section of dimension of 2 1/4 inches (57 mm).

2. **Type II.** Handrails with a perimeter greater than 6 1/4 inches (160 mm) shall provide a graspable finger recess area on both sides of the profile. The finger recess shall begin within a distance of 3/4 inch (19 mm) measured vertically from the tallest portion of the profile and achieve a depth of at least 5/16 inch (8 mm) with 7/8 inch (22 mm) below the widest portion of the profile. This required depth shall continue for at least 3/8 inch (10 mm) to a level that is not less than 1 3/4 inches (45 mm) below the tallest portion of the profile. The minimum width of the handrail above the recess shall be 1 3/4 inches (32 mm) to a maximum of 2 3/4 inches (70 mm). Edges shall have a minimum radius of 0.01 inch (0.25 mm).

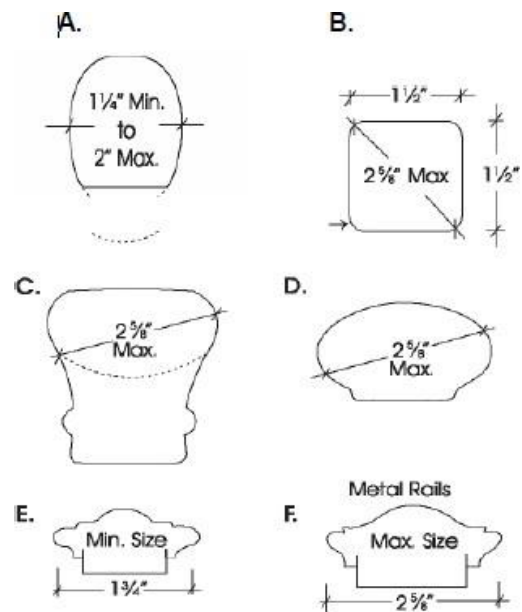

Figure 311.7

For SI: 1 inch = 25.4 mm; 1 degree = 0.018 rad

**SECTION R312
GUARDS AND WINDOW FALL PROTECTION**

R312.2 Guards at retaining walls. Where retaining walls with differences in grade level on either side of the wall is in excess of 30 inches and are located closer than 3 feet to a walk, designated walking path or driveway on the high side, such retaining wall shall be provided with guards that are

constructed in accordance with Section R312.1.2 and R312.1.3

SECTION R313

AUTOMATIC FIRE SPRINKLER SYSTEMS

R313 Automatic Fire Sprinkler Systems. Section R313.1 through R313.2.1 of the 2015 IRC shall be DELETED in their entirety.

SECTION R326

SWIMMING POOLS, SPAS AND HOT TUBS

R326.1 General. The provisions of this section shall control the design and construction of swimming pools, spas and hot tubs installed in or on the *lot* of a one- or two-family dwelling.

R326.2 Definitions. The following terms are defined in Chapter 2:

BARRIER

HOT TUB

IN-GROUND POOL

PRIVATE SWIMMING POOL

PRIVATE SWIMMING POOL, INDOOR

PRIVATE SWIMMING POOL, OUTDOOR

SPA

SWIMMING POOL

R326.3 Pools in flood hazard areas. Pools that are located in flood hazard areas established by the local jurisdiction or the flood plain manager including in-ground pools that involve placement of fill, shall comply with Section R326.3.1 or R326.3.2.

Exception: Pools located in riverine flood hazard areas which are outside of designated floodways.

R326.3.1 Pools located in designated floodways.

Where pools are located in designated floodways, documentation shall be submitted to the *building official* which demonstrates that the construction of the pool will not increase the design flood elevation at any point within the *jurisdiction*.

R326.3.2 Pools located where floodways have not been designated.

Where pools are located where design flood elevations are specified but floodways have not been designated, the applicant shall provide a floodway analysis that demonstrates that the proposed pool will not increase the design flood elevation more than 1 foot (305 mm) at any point within the *jurisdiction*.

R326.4 In-ground pools. In-ground pools shall be designed and constructed in compliance with ANSI/NSPI-5.

R326.5 Above-ground and on-ground pools. Above-ground and on-ground pools shall be designed and constructed in compliance with ANSI/NSPI-4.

R326.6 Pools in flood hazard areas. In flood hazard areas

established by Table R301.2 (1), pools in coastal high-hazard areas shall be designed and constructed in compliance with ASCE 24

R326.7 Permanently installed spas and hot tubs. Permanently installed spas and hot tubs shall be designed and constructed in compliance with ANSI/NSPI-3.

R326.8 Barrier Requirements. The provisions of this section shall control the design of barriers for residential swimming pools. These design controls are intended to provide protection against potential drownings and near - drownings by restricting access to swimming pools.

R326.8.1 Outdoor swimming pool. An outdoor in-ground swimming pool shall be surrounded by a barrier, which shall comply with the following:

1. The top of the barrier shall be at least 48 inches (1219 mm) above grade measured on the side of the barrier, which faces away from the swimming pool. The maximum vertical clearance between grade and the bottom of the barrier shall be 4 inches (102 mm) measured on the side of the barrier, which faces away from the swimming pool.
2. Openings in the barrier shall not allow the passage of a 4-inch-diameter (102 mm) sphere.
3. Solid barriers which do not have openings, such as a masonry or stone wall, shall not contain indentations or protrusions, except for normal construction tolerances and tooled masonry joints.
4. Where the barrier is composed of horizontal and vertical members, and the distance between the tops of the horizontal members is less than 24 inches (610 mm), the horizontal members shall be located on the swimming pool side of the fence. Spacing between vertical members shall not exceed 1 3/4 inches (44 mm) in width. Where there are decorative cutouts within vertical members, spacing within the cutouts shall not exceed 1 3/4 inches (44 mm) in width.

Exception: When intermediate horizontal members are located 34 inches (864 mm) or more above grade, the spacing between vertical members shall not exceed 4 inches (102 mm) in width.

5. Where the barrier is composed of horizontal and vertical members, and the distance between the tops of the horizontal members is 24 inches (610 mm) or more, spacing between vertical members shall not exceed 4 inches (102 mm). Where there are decorative cutouts within vertical members, spacing within the cutouts shall not exceed 1 3/4 inches (44 mm) in width.

6. Maximum mesh size for chain link fences shall be a 2 1/4-inch (57 mm) square, unless the fence has slats fastened at the top or the bottom which reduce the openings to not more than 1 3/4 inches (44 mm).
7. Where the barrier is composed of diagonal members, such as a lattice fence, the maximum opening formed by the diagonal members shall not be more than 1 3/4 inches (44 mm).
8. Access gates shall comply with the requirements of items 1 through 7, and shall be equipped to accommodate a locking device. Pedestrian access gates shall open outward away from the pool, and shall be self-closing and have a self-latching device. Gates, other than pedestrian access gates, shall have a self-latching device. Where the release mechanism of the self-latching device is located less than 48 inches (1219 mm) above grade from the bottom of the gate, the release mechanism and openings shall comply with the following:
 - 8.1. The release mechanism shall be located on the pool side of the gate at least 3 inches (76 mm) below the top of the gate; and
 - 8.2. The gate and barrier shall have no opening larger than 1/2 inch (12.7 mm) within 18 inches (457 mm) of the release mechanism.
9. Where a wall of a dwelling serves as part of the barrier, one of the following conditions shall be met:
 - 9.1. The pool shall be equipped with a powered safety cover in compliance with ASTM F 1346
 - 9.2. Doors with direct access to the pool through that wall shall be equipped with an alarm which produces an audible warning when the door and/or its screen, if present, are opened. The alarm shall be listed and labeled in accordance with UL 2017. The deactivation switch(es) shall be located at least 54 inches (1372 mm) above the threshold of the door; or
 - 9.3. Other means of protection, such as self-closing doors with self-latching devices, which are approved by the governing body, shall be acceptable as long as the degree of protection afforded is not less than the protection afforded by Item 9.1 or 9.2 described herein.

R326.8.2 Indoor swimming pool. Walls surrounding an indoor swimming pool shall comply with Item 9 of Section R926.6.2.

R326.8.3 Prohibited locations. Barriers shall be located to prohibit permanent structures, *equipment* or similar objects from being used to climb them.

R326.8.4 Barrier exceptions. Spas or hot tubs with a safety cover which comply with ASTM F 1346 shall be exempt from the provisions of this appendix.

R326.9 Locations. Private swimming pools shall not encroach on any front or side yard required by this code or by the governing zoning laws, unless in accordance with specific rules of the jurisdiction in which the pool is located. A wall of a swimming pool shall not be located less than 6 feet (1829mm) from any rear or side property lines or 10 feet (3048mm) from any street property line, unless in accordance with the specific rules of the jurisdiction in which the pool is located.

R326.10 Entrapment Protection for Swimming Pool and Spa Suction Outlets. Suction outlets shall be designed and installed in accordance with ANSI/APSP-7

SECTION R327 POST AND FRAME STRUCTURES

R327.1 Post and frame structures. The following requirements serve as minimum standards for post and frame structures within all of the following structural limitations:

1. Residential accessory structures
2. Single story
3. Metal roof on purlins with bracing and metal wall panels on girts, with bracing as shown in Figure R327.1 or in lieu of bracing provide solid exterior structural sheathing
4. No attic storage
5. Maximum building width of 48 feet including the overhang
6. Maximum wall height of 16 feet
7. Maximum mean roof height of 20 feet
8. Maximum post spacing of 8 feet

Post and frame structures and portions thereof outside the above structural limitations of this standard shall be accompanied by structural calculations as required by the residential building official or designed under the provisions of section R106.1 of the Kentucky Residential Code (KRC). Post and frame structure shall comply with the structural design requirements of Section R301 of the KRC or the alternative provisions (Post Frame Building Design Manual) referenced in Section 301.1.1.

R327.2 Definition. Post and frame structures consist of primary members (post, beams and single span trusses or ceiling joists and rafters) and secondary members (roof purlins, wall girts, bracing and sheathing) where all loads are transmitted from the sheathing and the secondary members to the primary members which transfer them to the ground through vertical posts bearing on footings embedded in the soil. See Figure R327.1.

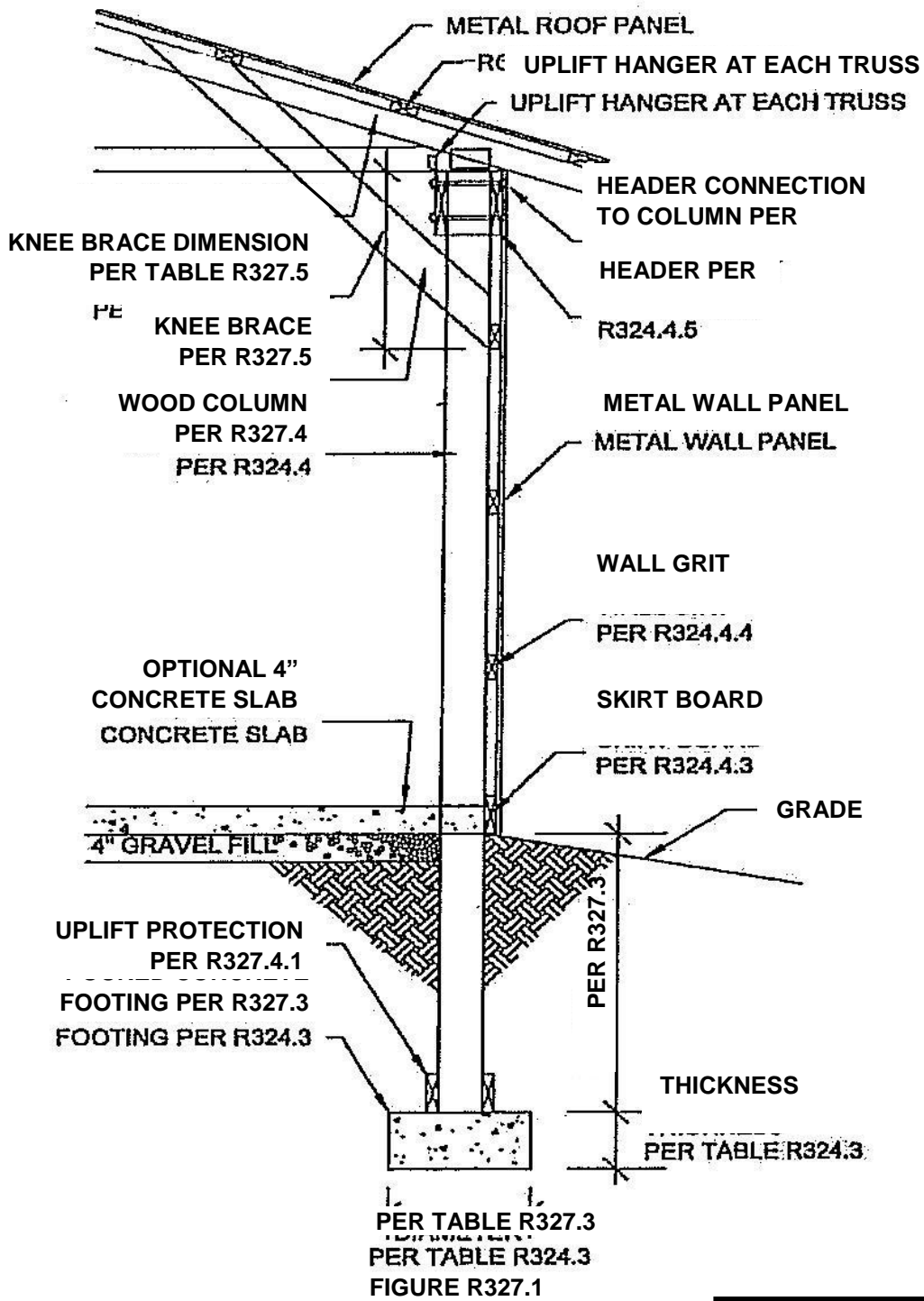

POST AND FRAME WALL SECTION
NO SCALE

BRACING NOT SHOWN

**TABLE R327.3
POST FRAME PIER DIAMETERS**

Building width (length of truss) including overhang (feet)							
	25	28	32	36	40	44	48
Diameter (inches) 20 lb. Roof Snow Load	18	22	24	26	28	28	30
Diameter (inches) 30 lb. Roof Snow Load	24	26	28	28	30	30	32

1. Pier footing thickness shall be a minimum one-half of the diameter of the footing.
2. Based upon 2000 PSF soil bearing capacity and truss loads of 20 or 30 PSF live or snow load top chord, 10 PSF dead load top chord, 5 PSF dead load on the bottom chord and no live load on the bottom chord.
3. Fractional widths shall be rounded to the next higher pier footing diameter.

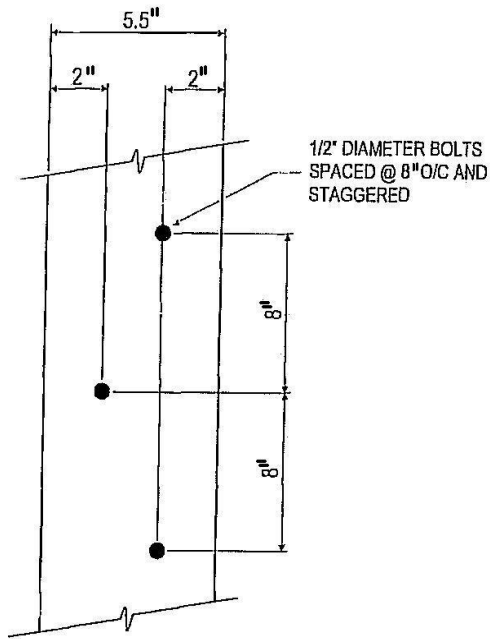

**BUILT UP COLUMN FASTENING DETAIL
FIGURE R327.2**

R327.3 Footings and Foundations. Footings and foundations shall comply with applicable provisions of R401. Post and frame structures shall have poured in-place concrete footings installed below all posts. The top of the footing shall be a minimum of 48 inches below finished grade and have footing diameters complying with Table R327.3.

R327.4 Column and wall construction. Columns shall be three sections of 4-ply unspliced, reinforced spliced or solid wood and shall not be less than 6-inch by 6-inch nominal size. Columns shall comply with the requirements of Section R318 and shall be restrained to prevent lateral displacement. Built up columns shall be fastened as illustrated in Figure R327.2.

R327.4.1 Column uplift protection. Columns shall have uplift protection by one of the following methods:

1. Two 2x6 12 inch column uplift protection blocks attached to each side of the base of the column. The column uplift protection blocks must be placed horizontally, attached per Table R327.7 and comply with Section R318.
2. 12 inch high, concrete collar poured on top of footing around the post with 2 #5x9 inch rebar placed through the post at 3 inches and 9 inches from bottom of post in opposite directions. The rebar ends shall be installed in accordance with ACI 332 for the specified distance in inches from contact with the soil. See Figure R327.3

R327.4.2 Column spacing. The maximum spacing for columns shall be 8 feet.

R327.4.3 Skirt boards. Skirt boards shall be treated lumber meeting the requirements of Section R318 and attached per Table R327.7.

R327.4.4 Wall girts. Girts shall be a minimum 2x4 spaced not more than 24 inches on center and attached per Table R327.7.

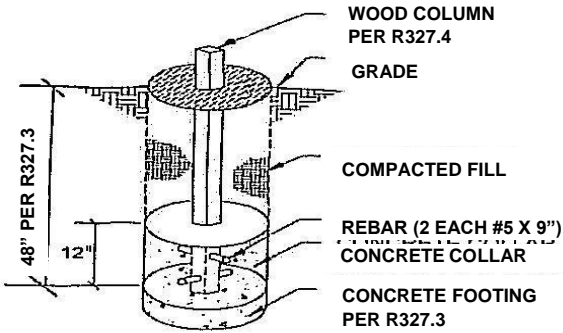

FIGURE R327.3
Column Uplift Protection Exception
No Scale
COLUMN UPLIFT PROTECTION EXCEPTION
NO SCALE

R327.4.5 Load bearing beams and headers. Load bearing beams and headers shall comply with Table R502.5 (1).

Exceptions:

1. Bearing beams are not required if the trusses or ceiling joists and rafters bear directly on the columns.
2. Opening on the gable end walls of post and frame buildings supporting a door or roof total load not exceeding 5 square feet per lineal feet of wall area, headers must be sized per Table R327.4.5.

TABLE R327.4.5
GABLE END HEADER SIZES

Opening Width (feet)	10	12	16
Header Size (inches)	2 - 2x8	2 - 2x10	2 - 2x12

R327.4.6 Exterior Structural Sheathing or Wall Bracing. Provide exterior structural sheathing or wall bracing to resist all racking and shear forces. Bracing must comply with the applicable provisions of section R602.10 or by installing 2x6 diagonal braces between two adjoining columns at 8 feet on center or multiple spacing totaling a minimum of 8 feet on center where the post spacing design is less than 8 feet on center. The diagonal brace shall be placed from the top header or girt to the next adjoining column at the skirt board. The bracing shall be installed on each side of the building and shall be a minimum of 25 feet on center and within 12 feet of the end of the building and attached to the wall girts and columns per Table R327.7. Any splices of the diagonal brace required due to excessive length, must lap over two consecutive wall girts.

R327.4.7 Beams supporting trusses or rafters and ceiling joists attachment to column. Bearing beams supporting roof trusses or rafters and ceiling joists shall be connected to columns by one of the following methods:

1. Bolts that are 1/2 inch diameter through-bolted to the side of the column;
2. Bolts that are 1/2 inch diameter, directly attached to a 3-ply column notch, enclosing the truss or rafter at the top of column; or
3. Other fasteners with minimum shear or withdraw values stated in Table R327.4.7.

R327.4.7.1 Number of fasteners. The minimum numbers of through bolts or the fasteners with minimum shears or withdraw values required per Table R327.4.7.

R327.5 Knee bracing. A 2x6 brace shall extend from the column to the top chord of the truss or rafter adjacent to the post at a 45 degree angle. The vertical distance down from the bottom chord of the truss or ceiling joist to the point where the brace attaches to the post shall be in compliance with Table R327.5 as shown on Figure R327.1. Trusses or rafter must be spaced such that they align with the column intervals. Attachment of knee brace shall be per Table R327.7.

TABLE R327.5
KNEE BRACE VERTICAL DISTANCE

Wall Height	Vertical Dimension
8'-0" and 9'-0"	1'-6"
10'-0" and 11'-0"	2'-0"
12'-0" and 13'-0"	3'-0"
14'-0" through 16'-0"	4'-0"

R327.6 Roof Construction. Top chord of roof trusses or roof rafters shall be braced with exterior sheathing or metal roof on purlins with bracing.

R327.6.1 Roof Purlins. Roof purlins shall be a minimum of 4x2 SPF #2 laid flat of spans up to 4 feet, and 4x2 SPF #2 laid on edge for spans up to 8 feet.

R327.6.2 Roof Bracing. Provide exterior structural sheathing or bracing to resist racking and shearing forces in roof. Bracing shall occur in the roof on all 4 sides of the building and shall consist of 2x6 diagonal braces perpendicular and parallel to rafters or trusses and attached to the bottom side of rafters or top chords of trusses. These braces shall start at a point just below the first purlin, rafter or truss in from the eave purlin and at each corner column. The brace shall be placed on a 45-degree angle and end below the location of a purlin, rafter or truss within 8'-0" in from the wall. If the building width or length exceeds 24'-0" then install additional braces in the same manner. Spacing of braces shall not exceed a maximum spacing of 2 feet on center in any direction.

R327.7 Attachment details. Structural fastener details for post and frame buildings shall comply with Table R327.7.

**TABLE R327.4.7
BEAM OR TRUSS CONNECTION AT COLUMNS MINIMUM FASTENERS OR TOTAL SHEAR OR
WITHDRAW VALUES**

Building width (length of truss) including overhang (feet)							
	24	28	32	36	40	44	48
Shear or withdraw (pounds) 20# snow load	3360	3920	4480	5040	5600	6160	6720
Number of Bolts 20# roof snow load	2	2	2	3	3	3	3
Shear or withdraw (pounds) 30# roof snow load	4320	5040	5760	6480	7200	7920	8640
Number of Bolts 30# roof snow load	2	3	3	3	3	3	3

1. Based upon truss loads of 20 or 30 PSF live or snow load top chord, 10 PSF dead load top chord, 5 PSF live load on the bottom chord and no live load on the bottom chord.
2. Based upon post spacing at intervals not exceeding 8 feet.
3. When beams are attached at each side of the column and fasteners do not extend through both beams such as through-bolts, the required values are one-half the amount shown above for each beam.

**TABLE R327.7
FASTENER SCHEDULE FOR STRUCTURAL MEMBERS**

Fastener Schedule for Structural Members		
Description of Building Element	Number and Type of Fastener	Attachment Type
Uplift blocking to column	5 – 16d Hot Dipped Galvanized	Each block
Skirt board to column	2 – 16d Hot Dipped Galvanized	Face nail
Wall girt to column	2 – 16d Hot Dipped Galvanized	Face nail
Diagonal bracing to column	2 – 16d Hot Dipped Galvanized	Toe nail
Diagonal bracing to skirt board	2 – 16d Hot Dipped Galvanized	Face nail
Diagonal bracing to wall girts	2 – 10d Hot Dipped Galvanized	Face nail
Knee brace to column	2 – 10d	Face nail
Knee brace to top chord of truss or rafter	3 – 16d Hot Dipped Galvanized	Face nail
Knee brace to bottom chord of truss or ceiling joist	3 – 10d	Face nail
	2 – 16d	Face nail

Roof purlin to truss or rafter with span of 2' or 4'		
Roof purlin to truss or rafter with span of 8'	Mechanical fastener with uplift protection greater than 225 lbs	Per manufacturer

**SECTION R328
TINY HOUSES
GENERAL**

R328.1 Scope. This section shall be applicable to tiny houses used as single dwelling units set on a permanent foundation. Tiny houses shall comply with the Kentucky Residential Code except as otherwise stated in this section.

R328.2 Definitions. The following words and terms shall have the meanings shown herein. Refer to Chapter 2 for general definitions.

**EGRESS ROOF ACCESS WINDOW
LANDING PLATFORM
LOFT
TINY HOUSE**

R328.3 Minimum ceiling height. Habitable space and hallways in tiny houses shall have a ceiling height not less than 6 feet 8 inches (2032 mm). Bathrooms, toilet rooms, and kitchens shall have a ceiling height not less than 6 feet, 4 inches (1930 mm). No obstructions shall extend below these minimum ceiling heights including beams, girders, ducts, lighting, or other obstructions.

Exception: Ceiling heights in lofts are permitted to be less than 6 foot 8 inches (2032 mm).

R328.4 Minimum loft areas. Lofts used as a sleeping or living space shall meet the minimum area and dimension requirements of Sections R328.4.1 through R328.4.3.

Exception: Under gable roofs with a minimum slope of 6:12, portions of a loft with a sloping ceiling measuring less than 16 inches (406 mm) from the finished floor to the finished ceiling shall not be considered as contributing to the minimum required area for the loft.

R328.4.1 Minimum area. Lofts shall have a floor area of not less than 35 square feet (3.25 m²)

R328.4.2 Minimum dimensions. Lofts shall be not less than 5 feet (1524 mm) in any horizontal dimension.

R328.4.3 Height effect on loft area. Portions of a loft with a sloping ceiling measuring less than 3 feet (914 mm) from the finished floor to the finished ceiling shall not be considered as contributing to the minimum required area for the loft.

R328.5 Loft access. The access to and primary egress from lofts shall be of any type described in Sections R328.4.2.1 through R328.4.2.4

R328.6 Stairways. Stairways accessing lofts shall comply with this code or with Sections R328.4.2.1.1 through R328.4.2.1.5

R328.6.1 Width. Stairways accessing a loft shall not be less than 17 inches (432 mm) in clear width at all points at or above the permitted handrail height. The minimum width below the handrail shall not be less than 20 inches (508 mm).

R328.6.2 Headroom. The headroom in stairways accessing a loft shall not be less than 6 feet 2 inches (1880 mm) measured vertically from the sloped line connecting the tread nosings in the middle of the tread width.

Exception: The headroom for landing platforms shall not be less than 4 feet 6 inches (1372 mm).

R328.6.3 Treads and Risers. Risers for stairs accessing a loft shall be a minimum of 7 inches (178 mm) and a maximum of 12 inches (305 mm). Tread depth and riser height shall be calculated with the following formulas:

$$\begin{aligned} \text{Tread depth} &= 20 \text{ inches (508 mm) minus } \frac{4}{3} \text{ riser height} \\ \text{or} \\ \text{Riser height} &= 15 \text{ inches (381 mm) minus } \frac{3}{4} \text{ tread depth} \end{aligned}$$

Exception: Landing platforms shall measure two treads deep and two risers tall.

R328.6.4 Handrails. Handrails shall comply with Section R311.7.8.

R328.6.5 Stairway guards. Guards at open sides of stairways shall comply with Section R312.1.

R328.7 Ladders. Ladders accessing lofts shall comply with Sections R328.7.1 and R328.4.7.2

R328.7.1 Size and capacity. Ladders accessing lofts shall have 12 inches (305 mm) minimum rung width and 10 inches (254 mm) to 14 inch (356 mm) spacing between rungs. Ladders shall be capable of supporting a 200 pound (75 kg) load on any rung. Rung spacing shall be uniform within 3/8-inch (9.5 mm).

R328.7.2 Incline. Ladders shall be installed at 70 to 80 degrees from horizontal.

R328.8 Alternating tread devices. Alternating tread devices accessing lofts shall comply with Sections R311.7.11.1 and R311.7.11.2. The clear width at and below the handrails shall be not less than 20 inches (508 mm).

R328.9 Ships ladders. Ships ladders accessing lofts shall comply with Sections R311.7.12.1 and R311.7.12.2. The clear width at and below the handrails shall be not less than 20 inches (508 mm).

R328.10 Loft guards. Loft guards shall be located along the open side(s) of lofts located more than 30 inches (762 mm) above the main floor. Loft guards shall be not less than 36 inches (914 mm) in height or one-half the clear height to the ceiling, whichever is less.

R328.11 Emergency escape and rescue openings. Tiny houses shall meet the requirements of Section R310 for emergency escape and rescue openings.

Exception: Egress roof access windows in lofts used as sleeping rooms shall be deemed to meet the requirements of Section R310 where installed with the bottom of their opening no more than 44 inches (1118 mm) above the loft floor

**CHAPTER 4
FOUNDATIONS**

**SECTION R401
GENERAL**

R401.1 Application. The provisions of this chapter shall control the design and construction of the foundation and foundation spaces for all buildings. In addition to the provisions of this chapter, the design and construction of foundations in areas prone to flooding as established by local jurisdiction shall meet the provisions of Section R322. Wood foundations shall be designed and installed in accordance with AF&PA PWF.

Exception: The provisions of this chapter shall be permitted to be used for wood foundations only in the following situations:

1. In building that have no more than two floors and a roof.
2. When interior basement and foundation wall are constructed at intervals not exceeding 50 feet (15240 mm).
3. Wood foundations in Seismic Design Category D₀, D₁ or D₂ shall be designed in accordance with accepted engineering practice.

R401.4.1 Geotechnical evaluation. In lieu of a complete geotechnical evaluation, the load-bearing values in Table R401.4.1 shall be assumed.

**TABLE R401.4.1
PRESUMPTIVE LOAD-BEARING VALUES OF
FOUNDATION MATERIALS^a**

CLASS OF MATERIAL	LOAD-BEARING PRESSURE (pounds per square foot)
Crystalline bedrock	12,000
Sedimentary and foliated rock	4,000
Sandy gravel and/or gravel (GW and GP)	3,000
Sand, silty sand, clayey sand, silty gravel and clayey gravel (SW, SP, SM, SC, GM and GC)	2,000
Clay, sandy clay, silty clay, clayey silt, silt and sandy silt (CL, ML, MH and CH)	1,500 ^{bc}

For SI: 1 pound per square foot = 0.0479 kPa.

- a. When soil tests are required by Section R401.4, the allowable bearing capacities of the soil shall be part of the recommendations.
- b. Where the building official determines that in-place soils with an allowable bearing capacity of less than 1,500 psf are likely to be present at the site, the allowable bearing capacity shall be determined by a soils investigation.

- c. 2000 psf presumptive load-bearing value shall be used for Boone, Campbell and Kenton counties for CL and CH soils only.

**SECTION R403
FOOTINGS**

R403.1.4 Minimum depth. The minimum depth of all exterior footings and foundation wall systems shall extend not less than the minimum frost-protection depths (MFPD) specified in Table R403.1.4 and Figure R403.1.4. The minimum frost depth shall be measured from the proposed finished grade to the bottom of the footing. All site fills shall be prepared in accordance with the requirements of Section R401.2. The minimum frost- protection depths specified in Table R403.1.4 may be achieved by backfilling with non-compacted soil above the base of the footing to a depth equal to or greater than the required frost depth plus an additional 4 inches (102 mm). The maximum grade slope for frost protection shall not exceed 2 to 1 and the minimum grade slope shall comply with the drainage requirements of Section R401.3.

Footing and foundation systems may be formed on top of the finished prepared site grade of the cut side of the excavation when the excavation cut exceeds 28 inches (711 mm) and the MFPD may be achieved by backfilling the cut slope.

The “finished prepared site grade” shall be defined as the area exposed after clearing, grubbing, topsoil removal, and grading of the building pad, exposing stable ground.

If solid rock is exposed during the preparation of the finished prepared site grade then the footing and foundation systems may bear on the solid rock and shall not be required to extend below the frost line specified in Table R403.1.4.

TABLE R403.1.4
MINIMUM FROST PROTECTION DEPTH FOR KENTUCKY

County	Frost Depth d_f (in)	County	Frost Depth d_f (in)	County	Frost Depth d_f (in)
Bell	27	Johnson	30	Magoffin	30
Boone	30	Kenton	30	Martin	33
Breathitt	30	Knott	33	Owsley	27
Campbell	30	Knox	27	Perry	30
Clay	27	Lawrence	27	Pike	33
Floyd	33	Leslie	30	All other KY Counties	24
Harlan	30	Letcher	33		

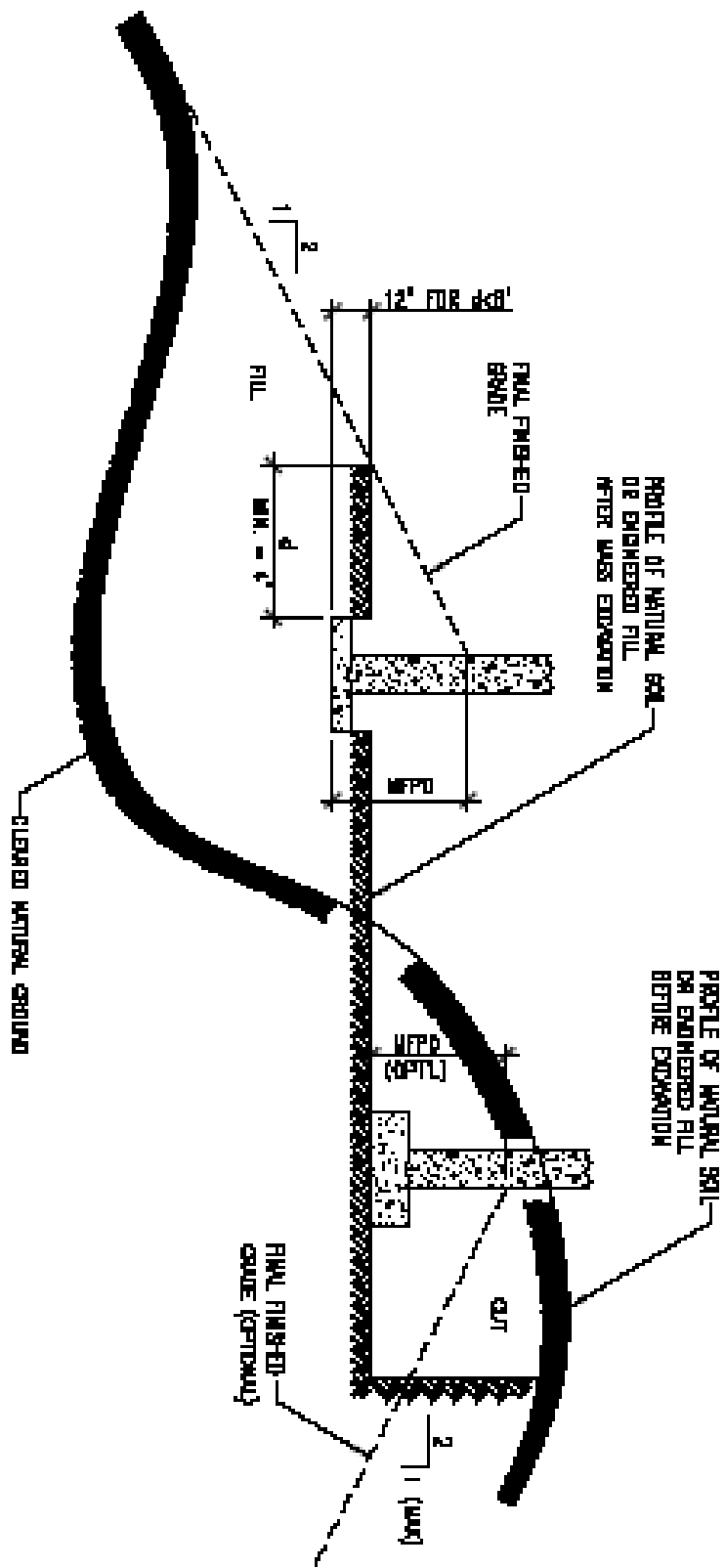

MFPD – MINIMUM FROST PROTECTION DEPTH
 FIGURE R403.1.4

**SECTION R404
FOUNDATION AND RETAINING WALLS**

**TABLE R404.1.2 (8)
MINIMUM VERTICAL REINFORCEMENT FOR 6-, 8-, 10-INCH AND 12-INCH NOMINAL FLAT BASEMENT
WALLS^{b, c, d, e, f, h, i, k, n}**

MAXIMUM WALL HEIGHT (feet)	MAXIMUM UNBALANCED BACKFILL HEIGHT ^g (feet)	MINIMUM VERTICAL REINFORCEMENT-BAR SIZE AND SPACING (inches)											
		Soil classes ^a and design lateral soil (psf per foot of depth)											
		GW, GP, SW, SP 30				GM, GC, SM, SM-SC and ML 45				SC, ML-CL and inorganic CL 60			
		Minimum nominal wall thickness (inches)											
		6	8	10	12	6	8	10	12	6	8	10	12
5	4	NR	NR	NR	NR	NR	NR	NR	NR	NR	NR	NR	NR
	5	NR	NR	NR	NR	NR	NR	NR	NR	NR	NR	NR	NR
6	4	NR	NR	NR	NR	NR	NR	NR	NR	NR	NR	NR	NR
	5	NR	NR	NR	NR	NR	NR ¹	NR	NR	4 @ 35	NR ¹	NR	NR
	6	NR	NR	NR	NR	5 @ 48	NR	NR	NR	5 @ 36	NR	NR	NR
7	4	NR	NR	NR	NR	NR	NR	NR	NR	NR	NR	NR	NR
	5	NR	NR	NR	NR	NR	NR	NR	NR	5 @ 47	NR	NR	NR
	6	NR	NR	NR	NR	5 @ 42	NR	NR	NR	6 @ 43	5 @ 48	NR ¹	NR
	7	5 @ 46	NR	NR	NR	6 @ 42	5 @ 46	NR ¹	NR	6 @ 34	6 @ 48	NR	NR
8	4	NR	NR	NR	NR	NR	NR	NR	NR	NR	NR	NR	NR
	5	NR	NR	NR	NR	4 @ 38	NR ¹	NR	NR	5 @ 43	NR	NR	NR
	6	4 @ 37	NR ¹	NR	NR	5 @ 37	NR	NR	NR	6 @ 37	5 @ 43	NR ¹	NR
	7	5 @ 40	NR	NR	NR	6 @ 37	5 @ 41 ²	NR ¹	NR	6 @ 34	6 @ 43	NR	NR
	8	6 @ 43	5 @ 47	NR ¹	NR	6 @ 34	6 @ 43	NR	NR	6 @ 27	6 @ 32	6 @ 44	NR
9	4	NR	NR	NR	NR	NR	NR	NR	NR	NR	NR	NR	NR
	5	NR	NR	NR	NR	4 @ 35	NR ¹	NR	NR	5 @ 40	NR	NR	NR
	6	4 @ 34	NR ¹	NR	NR	6 @ 48	NR	NR	NR	6 @ 36	6 @ 39	NR ¹	NR
	7	5 @ 36	NR	NR	NR	6 @ 34	5 @ 37	NR	NR	6 @ 33	6 @ 38	5 @ 37	NR ¹

	8	6 @ 38	5 @ 41	NR ^l	NR	6 @ 33	6 @ 38	5 @ 37 ^a	NR ^l	6 @ 24	6 @ 29	6 @ 39	4 @ 48 ^m
	9	6 @ 34	6 @ 46	NR	NR	6 @ 26	6 @ 30	6 @ 41	NR	6 @ 19	6 @ 23	6 @ 30	6 @ 39
10	4	NR	NR	NR	NR	NR	NR	NR	NR	NR	NR	NR	NR
	5	NR	NR	NR	NR	4 @ 33	NR ^l	NR	NR	5 @ 38	NR	NR	NR
	6	5 @ 48	NR ^l	NR	NR	6 @ 45	NR	NR	NR	6 @ 34	5 @ 37	NR	NR
	7	6 @ 47	NR	NR	NR	6 @ 34	6 @ 48	NR	NR	6 @ 30	6 @ 35	6 @ 48	NR ^l
	8	6 @ 34	5 @ 38	NR	NR	6 @ 30	6 @ 34	6 @ 47	NR ^l	6 @ 22	6 @ 26	6 @ 35	6 @ 45 ^m
	9	6 @ 34	6 @ 41	4 @ 48	NR ^l	6 @ 23	6 @ 27	6 @ 35	4 @ 48 ^m	DR	6 @ 22	6 @ 27	6 @ 34
	10	6 @ 28	6 @ 33	6 @ 45	NR	DR ^j	6 @ 23	6 @ 29	6 @ 38	DR	6 @ 22	6 @ 22	6 @ 28

For SI: 1 foot = 304.8 mm; 1 inch = 25.4 mm; 1 pound per square foot per foot = 0.1571 kPa²/m, 1 pound per square inch = 6.895 kPa.

NR = Not required.

- a. Soil classes are in accordance with the Unified Soil Classification System. Refer to Table R405.1.
- b. Table values are based on reinforcing bars with a minimum yield strength of 60,000 psi.
- c. Vertical reinforcement with a yield strength of less than 60,000 psi and/or bars of a different size than specified in the table are permitted in accordance with Section R404.1.2.3.7.6 and Table R404.1.2(9).
- d. NR indicates no vertical wall reinforcement is required, except for 6-inch nominal walls formed with stay-in-place forming systems in which case vertical reinforcement shall be #4@48 inches on center.
- e. Allowable deflection criterion is $L/240$, where L is the unsupported height of the basement wall in inches.
- f. Interpolation is not permitted.
- g. Where walls will retain 4 feet or more of unbalanced backfill, they shall be laterally supported at the top and bottom before backfilling.
- h. Vertical reinforcement shall be located to provide a cover of 1.25 inches measured from the inside face of the wall. The center of the steel shall not vary from the specified location by more than the greater of 10 percent of the wall thickness or $3/8$ -inch.
- i. Concrete cover for reinforcement measured from the inside face of the wall shall not be less than $3/4$ -inch. Concrete cover for reinforcement measured from the outside face of the wall shall not be less than $1\frac{1}{2}$ inches for No. 5 bars and smaller, and not less than 2 inches for larger bars.
- j. DR means design is required in accordance with the applicable building code, or where there is no code in accordance with ACI 318.
- k. Concrete shall have a specified compressive strength, f'_c , of not less than 2,500 psi at 28 days, unless a higher strength is required by footnote l or m.
- l. The minimum thickness is permitted to be reduced 2 inches, provided the minimum specified compressive strength of concrete, f'_c , is 4,000 psi.
- m. A plain concrete wall with a minimum nominal thickness of 12 inches is permitted, provided minimum specified compressive strength of concrete, f'_c , is 3,500 psi.
- n. See Table R608.3 for tolerance from nominal thickness permitted for flat walls.
- o. The use of this table shall be prohibited for soil classifications not shown.
- p. For a minimum 8-inch thick concrete wall with a minimum specified strength of concrete f'_c of 3000 psi, no wall reinforcement is required.

R404.1.5.2 Concrete wall thickness. The thickness of concrete foundation walls shall be equal to or greater than the thickness of the wall in the *story* above. Concrete foundation walls with corbels, brackets or other projections built into the wall for support of masonry

vener or other purposes are not within the scope of the tables in this section. Where a concrete foundation wall is reduced in thickness to provide a shelf for the support of masonry veneer, the reduced thickness shall be equal to or greater than the thickness of the wall in the *story*

above. Vertical reinforcement for the foundation wall shall be based on Table R404.1.2 (8) and located in the wall as required by Section R404.1.3.3.7.2 where that table is used. Vertical reinforcement shall be based on the thickness of the thinner portion of the wall.

Exceptions:

1. Where the height of the reduced thickness portion measured to the underside of the floor assembly or sill plate above is less than or equal to 24 inches (610 mm) and the reduction in thickness does not exceed 4 inches (102 mm), the vertical reinforcement is permitted to be based on the thicker portion of the wall.
2. Concrete foundation walls with a brick drop stem wall and located within Jefferson, Bullitt, Oldham, Spencer and Shelby counties which are known to have soil with sufficient stiffness, shall be permitted to comply with Figure R404.1.5. In seismic Design Categories D₀, D₁ and D₂, concrete foundation walls shall also comply with Section R404.1.4.

R404.1.9.2 Masonry piers supporting floor girders.

Masonry piers supporting wood girders sized in accordance with Tables R602.7 (1) and R602.7 (2) shall be permitted in accordance with this section. Piers supporting girders for interior bearing walls shall have a minimum nominal dimension of 12 inches (305 mm) and a maximum height of 10 feet (3048 mm) from top of footing to bottom of sill plate or girder. Piers supporting girders for exterior bearing walls shall have a minimum nominal dimension of 12 inches (305 mm) and a maximum height of 4 feet (1220 mm) from top of footing to bottom of sill plate or girder. Girders and sill plates shall be anchored to the pier or footing in accordance with Section R403.1.6 or Figure R404.1.5 (1). Floor girder bearing shall be in accordance with Section R502.6.

Exception: Interior piers shall not be required to be anchored to girders unless required by an engineered design.

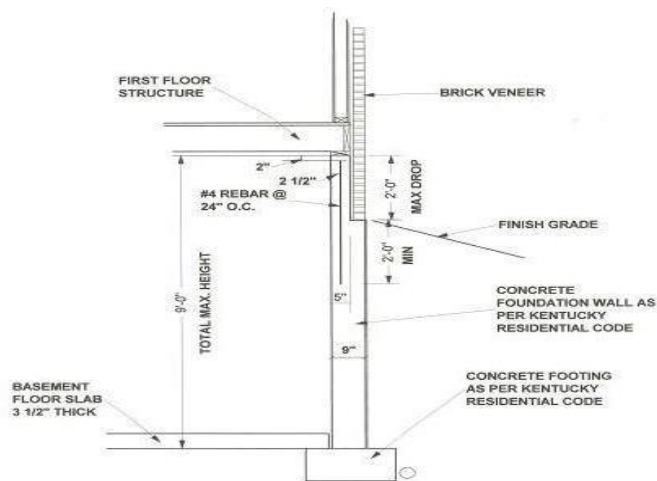

ALTERNATE FOUNDATION WALL/BRICK DROP SECTION

Figure R 404.1.5 (2)

CHAPTER 5 FLOORS

SECTION R502 WOOD FLOOR FRAMING

R502.6 Bearing. The ends of each joist, beam or girder shall have not less than 1.5 inches (38 mm) of bearing on wood or metal and not less than 3 inches (76 mm) on masonry or concrete except where supported on a 1-inch by 4-inch (25.4 mm by 102 mm) ribbon strip and nailed to the adjacent stud or by the use of approved joist hangers. The bearing on masonry or concrete shall be direct, or a sill plate of 2-inch-minimum (51 mm) nominal thickness shall be provided under the joist, beam or girder. The sill plate shall provide a minimum nominal bearing area of 48 square inches (30 865 square mm). A shim of metal or 1-inch nominal hardwood shall be acceptable to fill the void between joist, beam or girder and sill plate.

Steel columns, posts, and beams must be erected and installed according to manufacturer's instructions (if applicable). Unless otherwise listed and approved for specific use, nail/ram gun applications are prohibited in the installation of steel columns, posts, and beams (flanges and right angle clips) in residential construction. Anchors of proper size and strength (no less than ½ inch or according to the manufacturer's instructions) must be used and installed for the correct number of holes in each base plate or clip. All clips and column or post plates must be welded to the beam(s) by a weld in accordance with AISC 360 across the full width of two or more sides, or secured with at least two, ½ inch diameter bolts for columns or posts weighting 300 pounds or less, and four 1/2 inch diameter bolts for all other cases.

R502.9 Fastening. Floor framing shall be nailed in accordance with Table R602.3 (1). Where post and beam or girders construction is used to support framing, positive connections shall be provided to ensure against uplift and lateral displacement. The fastening of steel columns, posts, and beams shall be in accordance with the manufacturers installation instructions or in accordance with Table R602.3 (1).

SECTION R507 EXTERIOR DECKS

R507.2.2 Alternate deck ledger connections. Deck ledger connections not conforming to Table R507.2 shall be designed in accordance with accepted engineering practice. Girders supporting deck joists shall not be supported on deck ledgers or band joists. Deck ledgers shall not be supported on stone or masonry veneer unless specifically designed by a design professional, or supported by an approved listed and labeled fastening method.

**CHAPTER 6
WALL CONSTRUCTION**

**SECTION R602
WOOD WALL FRAMING**

R602.12 Simplified Wall Bracing. A prescriptive alternative for braced wall compliance with the Kentucky Residential Code shall be as follows. All one and two family *dwelling*s and *townhouses* located in a Seismic Design Category A, B and C as constructed through the prescriptive allowance of the adopted code and are sheathed entirely on the exterior of the structure with one of the following approved methods:

1. Wood structural panels conforming to R602.1.8, being a minimum 7/16-inch thick and fastened with the wood structural panel fastening schedule in Table R602.3 (1) or Table R602.3 (2).
2. Any Alternate Structural method, having been evaluated by an ANSI/ACASS ISO 17065 agency and demonstrating Structural performance under lateral load conditions (wind and seismic) for use as an alternative to the Kentucky Residential Code Intermittent Wall Bracing provisions of Section R602.10 method WSP. The Alternate Structural Method must have a current Evaluation Report sealed by a Kentucky licensed Design Professional.

Either of the two methods shall be considered compliant with the following sections R602.10 and R602.12 outlining prescriptive and braced wall requirements. All one and two family *dwelling*s and *townhomes* located in Seismic Design Category D, D₀, D₁, D₂, shall be constructed per the prescriptive allowances as outlined in the following sections R602.10 and R602.12.

CHAPTER 7
WALL COVERING

SECTION R703
EXTERIOR COVERING

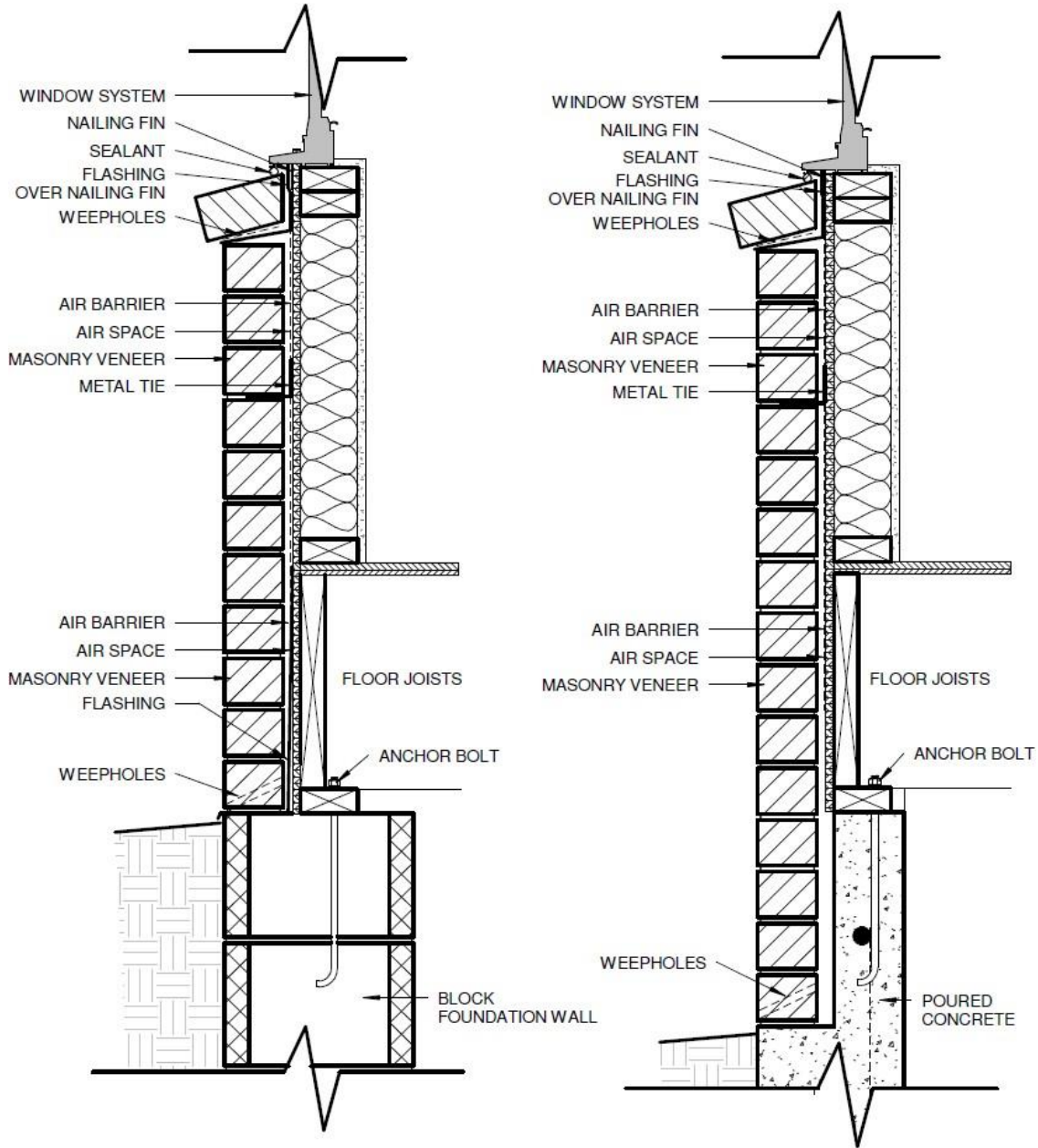

**TABLE R703.8.4
TIE ATTACHMENT AND AIR SPACE REQUIREMENTS**

BACKING AND TIE	MINIMUM TIE	MINIMUM TIE FASTENER^a	AIR SPACE	
Wood stud backing with corrugated sheet metal	22 U.S. gage (0.0299 in.) × 7/8 in. wide	8d common nail ^{b,c} (2½ in. × 0.131 in.)	Nominal ¾ in. between sheathing and veneer	
Wood stud backing with metal strand wire	W1.7 (No. 9 U.S. gage; 0.148 in.) with hook embedded in mortar joint	8d common nail ^{b,c} (2½ in. × 0.131 in.)	Minimum nominal ¾ in. between sheathing and veneer	Maximum 4½ in. between backing and veneer
Cold-formed steel stud backing with adjustable metal strand wire	W1.7 (No. 9 U.S. gage; 0.148 in.) with hook embedded in mortar joint	No. 10 screw extending through the steel framing a minimum of three exposed threads	Minimum nominal ¾ in. between sheathing and veneer	Maximum 4½ in. between backing and veneer

For SI: 1 inch = 25.4 mm.

- a. In Seismic Design Category D₀, D₁ or D₂, the minimum tie fastener shall be an 8d ring-shank nail (2½ in. × 0.131 inch) or a No. 10 screw extending through the steel framing a minimum of three exposed threads.
- b. All fasteners shall have rust-inhibitive coating suitable for the installation in which they are being used, or be manufactured from material not susceptible to corrosion.
- c. All Fasteners shall penetrate a stud or wood structural panel.

CHAPTER 9 ROOF ASSEMBLIES

SECTION R905 REQUIREMENTS FOR ROOF COVERINGS

R905.2.8.5 Drip edge. A drip edge shall be provided at eaves and gables of shingle roofs. Adjacent pieces of drip edge shall be overlapped a minimum of 2 inches (51 mm). Drip edges shall extend a minimum of 0.25 inch (6.4 mm) below the roof sheathing and extend up the roof deck a minimum of 2 inches (51 mm). Drip edges shall be mechanically fastened to the roof deck at a maximum of 12 inches (305 mm) on center with fasteners as specified in Section R905.2.5. Underlayment shall be installed over the drip edge along eaves and under the drip edge on gables. Alternate methods to the standard metal drip edge may include site formed coil stock that creates a drip line as intended by the code. Wood, composite and manufactured trim installed on the fascia shall create a drip line to prevent water from running back under the shingles which will meet the requirements of the drip edge.

CHAPTER 11 ENERGY EFFICIENCY

SECTION N1101 GENERAL

N1101.1 Scope. This chapter regulates the energy efficiency for the design and construction of buildings regulated by the 2009 *International Energy Conservation Code*.

N1101.2 Compliance. Compliance shall be demonstrated by meeting the requirements of the International Energy Conservation Code and Sections N1101.2.1 and N1101.2.2 of this code where applicable.

N1101.2.1 Basement walls. Walls associated with *basements* that make up the building thermal envelope shall be insulated from the inside or outside of the basement wall from the top of the basement wall below grade to the design frost depth in accordance with Section R403.1.4. Walls associated with unconditioned *basements* shall meet this requirement unless the floor overhead is insulated in accordance with Sections 402.1.1 and 402.2.6 of the 2009 *International Energy Conservation Code*.

N1101.2.2 Slab on grade floors. Slab on grade floors constructed in accordance with Figure N1101.2.2 shall be permitted as an alternative insulation method.

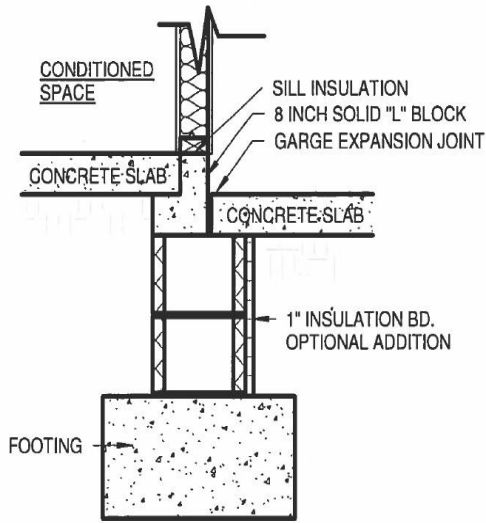

FOUNDATION DETAIL
GARAGE

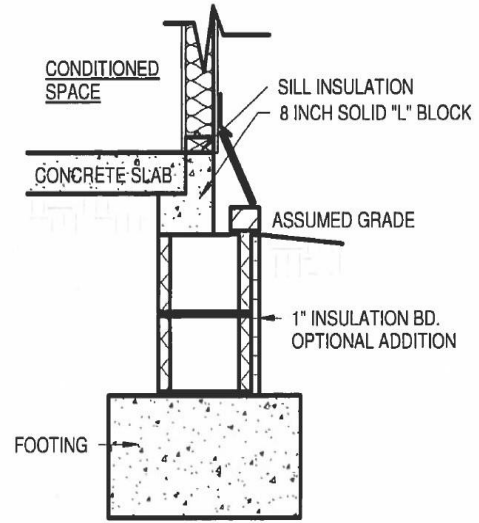

FOUNDATION DETAIL
SIDING/ PAVER

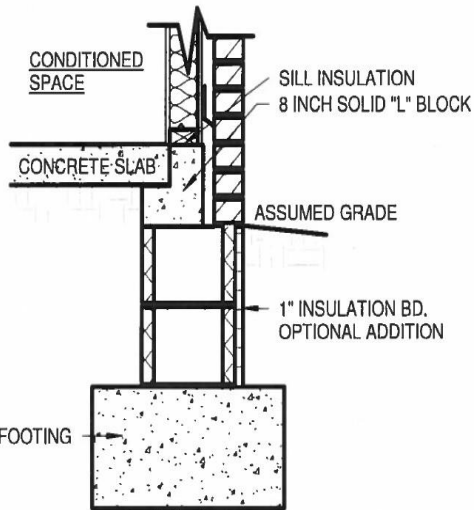

FOUNDATION DETAIL
BRICK DROP

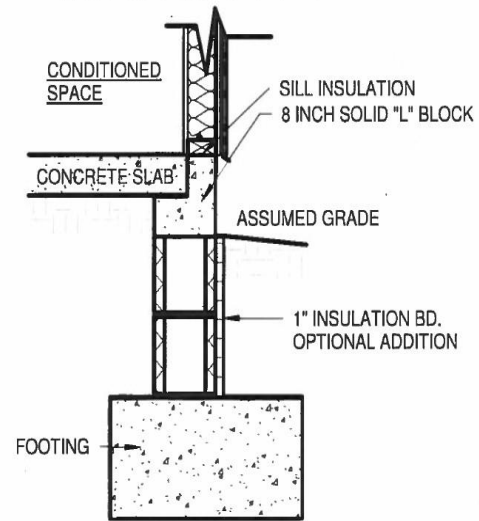

FOUNDATION DETAIL
SIDING/ PAVER

Figure N1101.2.2
Alternative insulation method for slab on grade floors

CHAPTER 13
GENERAL MECHANICAL SYSTEM REQUIREMENTS

SECTION M1301
GENERAL

M1301.1. Scope. The provisions of this chapter shall govern the installation of mechanical systems not specifically covered in other chapters applicable to mechanical systems. Installation of mechanical appliances, equipment and systems not addressed by this code shall comply with the applicable provisions of the International Mechanical Code and NFPA 54 National Fuel Gas Code.

SECTION M1305
APPLIANCE ACCESS

M1305.1 Appliance access for inspection service, repair and replacement. *Appliances* shall be accessible for inspection, service, repair and replacement without removing permanent construction, other *appliances*, or any other piping or ducts not connected to the *appliance* being inspected, serviced, repaired or replaced. A level working space not less than 30 inches deep and 30 inches wide (762 mm by 762 mm) shall be provided in front of the control side to service an *appliance*.

Exception: Structural members located within the 30-inch by 30-inch work space shall be acceptable if it does not impede serviceability of the equipment.

M1305.1.3 Appliances in attics. *Attics* containing *appliances* shall be provided with an opening and a clear and unobstructed passageway large enough to allow removal of the largest *appliance*, but not less than 30 inches (762 mm) high and 22 inches (559 mm) wide and not to exceed half the length of the structure from the opening to the *appliance*. The passageway shall have continuous solid flooring in accordance with Chapter 5 not less than 24 inches (610 mm) wide. A level service space not less than 30 inches (762 mm) deep and 30 inches (762 mm) wide shall be present along all sides of the *appliance* where access is required. The clear access opening dimensions shall be not less than of 20 inches by 30 inches (508 mm by 762 mm), and large enough to allow removal of the largest appliance.

Exceptions:

1. The passageway and level service space are not required where the *appliance* can be serviced and removed through the required opening.
2. Where the passageway is unobstructed and not less than 6 feet (1829 mm) high and 22 inches (559 mm) wide for its entire length, the passageway shall be not more than 50 feet (15 250 mm) long.

M1305.1.4 Appliances under floors. Underfloor spaces containing *appliances* shall be provided with an unobstructed passageway large enough to remove the largest *appliance*, but not less than 30 inches (762 mm) high and 22 inches (559 mm) wide, nor more than half the length of the structure from the opening to the *appliance*. A level service space not less than 30 inches (762 mm) deep and 30 inches (762 mm) wide shall be present at the front or service side of the *appliance*. If the depth of the passageway or the service space exceeds 12 inches (305 mm) below the adjoining grade, the walls of the passageway shall be lined with concrete or masonry extending 4 inches (102 mm) above the adjoining grade in accordance with Chapter 4. The rough-framed access opening dimensions shall be not less than 22 inches by 30 inches (559 mm by 762 mm), and large enough to remove the largest *appliance*.

Exceptions:

1. The passageway is not required where the level service space is present when the access is open, and the *appliance* can be serviced and removed through the required opening.
2. Where the passageway is unobstructed and not less than 6 feet high (1929 mm) and 22 inches (559 mm) wide for its entire length, the passageway shall not be limited in length.

CHAPTER 14
HEATING AND COOLING EQUIPMENT AND APPLIANCES

SECTION M1403
HEAT PUMP EQUIPMENT

M1403.1 Heat pumps. Electric heat pumps shall be listed and labeled in accordance with UL 1995 or UL/CSA/ANCE 60335-2-40 and installed in accordance with the manufacturer's installation instructions.

SECTION M1411
HEATING AND COOLING EQUIPMENT

M1411.8 Locking access port caps. Section M1411.8 shall be DELETED in its entirety.

SECTION M1416
MINI-SPLIT HEAT PUMPS

M1416.1 General. Mini-split heat pumps shall be installed in accordance with Section R303.9 and the manufacturer's installation instructions.

CHAPTER 15 EXHAUST SYSTEMS

SECTION M1502 CLOTHES DRYER EXHAUST

M1502.4.1.1 Alternate Material and installation. Clothes dryer exhaust ducts are permitted to be made of PVC and CPVC plastic provided they shall be a nominal 4 inches in diameter. The alternate material shall only be installed below a slab on grade floor and backfilled with sand or gravel. Each dryer exhaust duct joint shall be secured with PVC or CPVC solvent glue and each joint shall provide a smooth interior finish. The maximum installed exhaust duct length shall conform to Section M1502.4.4.1 and labeled in accordance with Section M1502.4.5. The dryer exhaust duct shall be installed to provide positive drainage to the termination and shall not permit the collection of condensate. The exhaust duct shall only extend a maximum of 1 inch above the slab on grade floor for connection to the appliance.

M1502.4.4.1 Accessibility and identification. Dryer exhaust duct power ventilators shall be accessible for inspection, service, repair and replacement without removing permanent construction and identified on a permanent label or tag at the appliance or access door to the appliance. A permanent label or tag giving notification to the occupant of the use of a dryer exhaust duct power ventilator shall be located within 6 feet (1829 mm) of the dryer.

SECTION M1503 RANGE HOODS

M1503.2 Duct material. Ducts serving range hoods shall be constructed of galvanized steel, stainless steel, copper, or other manufacturer approved material.

Exception: Ducts for domestic kitchen cooking *appliances* equipped with down-draft exhaust systems shall be permitted to be constructed of schedule 40 PVC pipe and fittings provided that the installation complies with all of the following:

1. The duct is installed under a concrete slab poured on grade.
2. The underfloor trench in which the duct is installed is completely backfilled with sand or gravel.
3. The PVC duct extends not more than 1 inch (25 mm) above the indoor concrete floor surface.
4. The PVC duct extends not more than 1 inch (25 mm) above grade *outside of the building*.
5. The PVC ducts are solvent cemented.

M1503.4 Makeup air required. Exhaust hood systems capable of exhausting in excess of 400 cubic feet per minute (0.19 m³/s) shall be mechanically or naturally provided with makeup air at a rate approximately equal to the exhaust air rate. Such makeup air systems shall be equipped with not less than one damper. Each damper shall be an electrically operated damper that automatically opens when the exhaust system operates. Dampers shall be accessible for inspection, service, repair and replacement without removing permanent construction or any other ducts not connected to the damper being inspected, serviced, repaired or replaced.

CHAPTER 16 DUCT SYSTEMS

SECTION M1601 DUCT CONSTRUCTION

M1601.4.1 Joints, seams and connections. Longitudinal and transverse joints, seams and connections in metallic and nonmetallic ducts shall be constructed as specified in SMACNA HVAC *Duct Construction Standards—Metal and Flexible* and NAIMA *Fibrous Glass Duct Construction Standards*. Joints, longitudinal and transverse seams, and connections in ductwork shall be securely fastened and sealed with welds, gaskets, mastics (adhesives), mastic-plus-embedded-fabric systems, liquid sealants or tapes.

Tapes and mastics used to seal fibrous glass ductwork shall be *listed* and *labeled* in accordance with UL 181A and shall be marked “181A-P” for pressure-sensitive tape, “181 A-M” for mastic or “181 A-H” for heat-sensitive tape.

Tapes and mastics used to seal flexible air ducts and flexible air connectors shall comply with UL 181B and shall be marked “181 B-FX” for pressure-sensitive tape or “181 BM” for mastic. Duct connections to flanges of air distribution system equipment shall be sealed and mechanically fastened. Mechanical fasteners for use with flexible nonmetallic air ducts shall comply with UL 181B and shall be marked 181B-C. Crimp joints for round metallic ducts shall have a contact lap of not less than 1 inch (25 mm) and shall be mechanically fastened by means of not less than three sheet-metal screws or rivets equally spaced around the joint.

Closure systems used to seal all ductwork shall be installed in accordance with the manufacturers’ instructions.

Exceptions:

1. Spray polyurethane foam shall be permitted to be applied without additional joint seals.
2. Where a duct connection is made that is partially inaccessible, three screws or rivets shall be equally spaced on the exposed portion of the joint so as to prevent a hinge effect.
3. Continuously welded and locking-type longitudinal joints and seams in ducts operating at static pressures less than 2 inches of water column (500 Pa) pressure classification shall not require additional closure systems.

**CHAPTER 17
COMBUSTION AIR**

Chapter 17 Combustion Air. Chapter 17 of the 2015 IRC shall be DELETED in their entirety.

**CHAPTER 18
CHIMNEYS AND VENTS**

Chapter 18 Chimneys and Vents. Chapter 18 of the 2015 IRC shall be DELETED in its entirety.

**CHAPTER 19
SPECIAL APPLIANCES, EQUIPMENT AND SYSTEMS**

Chapter 19 Special Appliances, Equipment and Systems. Chapter 19 of the 2015 IRC shall be DELETED in its entirety.

**CHAPTER 20
BOILERS AND WATER HEATERS**

Chapter 20 Boilers and Water Heaters. Chapter 20 of the 2015 IRC shall be DELETED in its entirety.

**CHAPTER 24
FUEL GAS**

Chapter 24 Fuel Gas. Chapter 24 of the 2015 IRC shall be DELETED in its entirety.

**CHAPTER 25
PLUMBING ADMINISTRATION**

Chapter 25 Plumbing Administration. Chapter 25 of the 2015 IRC shall be DELETED in its entirety.

**CHAPTER 26
GENERAL PLUMBING REQUIREMENTS**

Chapter 26 General Plumbing Requirements. Chapter 26 of the 2015 IRC shall be DELETED in its entirety.

**CHAPTER 27
PLUMBING FIXTURES**

Chapter 27 Plumbing Fixtures. Chapter 27 of the 2015 IRC shall be DELETED in its entirety.

**CHAPTER 28
WATER HEATERS**

Chapter 28 Water Heaters. Chapter 28 of the 2015 IRC shall be DELETED in its entirety.

**CHAPTER 29
WATER SUPPLY AND DISTRIBUTION**

Chapter 29 Water Supply and Distribution. Chapter 29 of the 2015 IRC shall be DELETED except for Section P2904 Dwelling Unit Fire Sprinkler Systems.

**CHAPTER 30
SANITARY DRAINAGE**

Chapter 30 Sanitary Drainage. Chapter 30 of the 2015 IRC shall be DELETED in its entirety.

**CHAPTER 31
VENTS**

Chapter 31 Vents. Chapter 31 of the 2015 IRC shall be DELETED in its entirety.

**CHAPTER 32
TRAPS**

Chapter 32 Traps. Chapter 32 of the 2015 IRC shall be DELETED in its entirety.

**CHAPTER 33
STORM DRAINS**

Chapter 33 Storm Drains. Chapter 33 of the 2015 IRC shall be DELETED in its entirety.

**CHAPTER 34
GENERAL REQUIREMENTS**

Chapter 34 General Requirements. Chapter 34 of the 2015 IRC shall be DELETED in its entirety.

**CHAPTER 35
ELECTRICAL DEFINITIONS**

Chapter 35 Electrical Definitions. Chapter 35 of the 2015 IRC shall be DELETED in its entirety.

**CHAPTER 36
SERVICES**

Chapter 36 Services. Chapter 33 of the 2015 IRC shall be DELETED in its entirety.

**CHAPTER 37
BRANCH CIRCUIT AND FEEDER REQUIREMENTS**

Chapter 37 Branch Circuit and Feeder Requirements. Chapter 37 of the 2015 IRC shall be DELETED in its entirety.

**CHAPTER 38
WIRING METHODS**

Chapter 38 Wiring Methods. Chapter 38 of the 2015 IRC shall be DELETED in its entirety.

**CHAPTER 39
POWER AND LIGHTING DISTRIBUTION**

Chapter 39 Power and Lighting Distribution. Chapter 39 of the 2015 IRC shall be DELETED in its entirety.

**CHAPTER 40
DEVICES AND LUMINAIRES**

Chapter 40 Devices and Luminaires. Chapter 40 of the 2015 IRC shall be DELETED in its entirety.

**CHAPTER 41
APPLIANCE INSTALLATION**

Chapter 41 Vents. Chapter 41 of the 2015 IRC shall be DELETED in its entirety.

**CHAPTER 42
SWIMMING POOLS**

Chapter 42 Swimming Pools. Chapter 42 of the 2015 IRC shall be DELETED in its entirety.

**CHAPTER 43
CLASS 2 REMOTE-CONTROL, SIGNALING AND POWER-LIMITED CIRCUITS**

Chapter 43 Class 2 Remote-Control, Signaling and Power-Limited Circuits. Chapter 43 of the 2015 IRC shall be DELETED in its entirety.

**CHAPTER 44
REFERENCED STANDARDS**

AWC

American Wood
Council 222 Catocin
Circle, Suite 201
Leesburg, VA 20175

Standard Reference Number	Title	Referenced in code section number
AWC PRWDC6---2012	Prescriptive Residential Wood Deck Construction guide.....	R301.1.1

ANSI

American National Standards Institute
25 West 43rd Street 4th Floor
New York NY 10036

Standard Reference Number	Title	Referenced in code section number
ANSI/NSPI 3-99	Standard for Permanently Installed Residential Spas	R326.4.1
ANSI/NSPI 5-03	Standard for Residential In-ground Swimming Pools.....	R326.3.1
ANSI/APSP 7-06	Standard for Suction Entrapment Avoidance in Swimming Pools, Wading Pools, Spas, Hot Tubs And Catch Basins.....	R326.6.1

ASTM

ASTM International
100 Barr Harbor Drive
West Conshohocken PA 19428

Standard Reference Number	Title	Referenced in code section number
ASTM F 1346 – 91	Performance Specification (2003) for Safety Covers and Labeling Requirements for All Covers for Swimming Pools Spas and Hot Tubs.....	R326.6.2

KY CODES

Department of Housing,
Buildings and Construction
101 Sea Hero Road, Suite 100
Frankfort, Kentucky 40601-5412

Standard Reference Number	Title	Referenced in code section number
---------------------------	-------	-----------------------------------

KSPC Kentucky State Plumbing Code..... Chapters 25 through 32
 KSB & PV & PL-03 Kentucky State Boiler and Pressure Vessel and Piping Law.....M2001.1

FEMA Federal Emergency Management Agency
 500C. Street SW
 Washington,D.C.20472

Standard Reference Number	Title	Referenced in code section number
	FEMA 232 – June, 2006 Home Builders Guide to Seismic Resistant Construction.....	R301.1.1, R301.2.2

ICC International Code Council, Inc.
 500 New Jersey Avenue, NW
 6th Floor
 Washington, DC 20001

Standard Reference Number	Title	Referenced in code section number
IECC—09	International Energy Conservation Code®N1101.2, N1101.5, N1101.13.1
*IFGC—15International Fuel Gas Code®, IPC—15International Plumbing Code®, IPMC—15International Property Maintenance Code®, IPSDC—15International Private Sewage Disposal Code®, ISPSC—15 International Swimming Pool and Spa Code™ are deleted in the entirety and are not included as references by the Kentucky Residential Code.		

NFBA National Frame Builders Association
 8735 W Higgins Road suite 300
 Chicago IL 60631

Standard Reference Number	Title	Referenced in code section number
2 nd Edition	Post Frame Building Design Manual.....	R301.1.1

NFPA National Fire Protection Association
 1 Batterymarch Park
 Quincy, MA 02269-9101

Standard Reference Number	Title	Referenced in code section number
54-09	National Fuel Gas Code.....	M1301.1, M1701.1, M1801.1, M2001.1, G2401.1
70—17	National Electrical CodeR102.9